

# User Guide

## MD200 Series AC Drive



## Revision History

Date	Version	Change Description
January 2016	V0.0	Related firmware version: F7-10 = U10.05 and F7-11 = U0.06
March 2016	A01	Related firmware version: F7-10 = U10.06 and F7-11 = 001.00
November 2016	A02	<ul style="list-style-type: none"> <li>◆ Modified the information in Approvals, designation rule and, nameplate.</li> <li>◆ Added information of three-phase models.</li> </ul>
May 2017	A03	<ul style="list-style-type: none"> <li>◆ Modified information of three-phase models.</li> <li>◆ Modified information of parameters.</li> <li>◆ Added information of mechanical installation and CE certification.</li> </ul>
September 2017	A04	<ul style="list-style-type: none"> <li>◆ Added information of single-phase and three-phase -NC models.</li> <li>◆ Added description of F4-04.</li> <li>◆ Added information of the three-phase filter and reactor model selection.</li> </ul>
August 2020	A05	<ul style="list-style-type: none"> <li>◆ Updated Inovance's logo.</li> <li>◆ Updated the nameplate in "1.1 Product Information."</li> <li>◆ Updated "2.2.1 Wiring Diagrams."</li> <li>◆ Updated "2.2.3 Wiring of Control Signal Input Terminals."</li> <li>◆ Updated the output voltage in "5.2.1 Rated Data".</li> <li>◆ Added the data of thermal design power and air flow in "5.2.2 Technical Specifications."</li> <li>◆ Added information of the fuse in "5.3 Selection of Electrical Peripherals."</li> <li>◆ Added "5.6 Selection of Cables and Tightening Torque."</li> <li>◆ Added "5.7 Selection of Options."</li> </ul>
Dec. 2020	A06	<ul style="list-style-type: none"> <li>◆ Added note for A0 group of parameters.</li> <li>◆ Modified the descriptions of A1 group of parameters.</li> </ul>

The following table lists the certificates and standards that the product may comply with. For details about the acquired certificates, see the certification marks on the product nameplate.

Name	Directive Name		Standard
CE certification	EMC directive	2014/30/EU	EN 61800-3
	LVD directive	2014/35/EU	EN 61800-5-1
	RoHS directive	2011/65/EU	EN 50581
TUV	-	-	EN 61800-5-1
UL certification	-	-	UL61800-5-1 C22.2 No.14-13

- This user guide is shipped with the product. For any question or query, contact your sales representative.
- To obtain the user guide, access Inovance's website (<http://www.inovance.com>), click "Download", search for the user guide by its name, and then download the PDF file.

# Safety Instructions

## Safety Precautions

- 1) Before installing, using, and maintaining this equipment, read the safety information and precautions thoroughly, and comply with them during operations.
- 2) To ensure the safety of humans and equipment, follow the signs on the equipment and all the safety instructions in this user guide.
- 3) "CAUTION", "WARNING", and "DANGER" items in the manual do not indicate all safety precautions that need to be followed; instead, they just supplement the safety precautions.
- 4) Use this equipment according to the designated environment requirements. Damage caused by improper usage is not covered by warranty.
- 5) Inovance shall take no responsibility for any personal injuries or property damage caused by improper usage.

## Safety Levels and Definitions



indicates that failure to comply with the notice will result in severe personal injuries or even death.



indicates that failure to comply with the notice may result in severe personal injuries or even death.



indicates that failure to comply with the notice may result in minor personal injuries or damage to the equipment.

## Safety Instructions

Unpacking	
	<ul style="list-style-type: none"><li>◆ Check whether the packing is intact and whether there is damage, water seepage, damp, and deformation.</li><li>◆ Unpack the package by following the package sequence. Do not hit the package with force.</li><li>◆ Check whether there are damage, rust, or injuries on the surface of the equipment or equipment accessories.</li><li>◆ Check whether the number of packing materials is consistent with the packing list.</li></ul>



- ◆ Do not install the equipment if you find damage, rust, or indications of use on the equipment or accessories.
- ◆ Do not install the equipment if you find water seepage, component missing or damage upon unpacking.
- ◆ Do not install the equipment if you find the packing list does not conform to the equipment you received.

#### Storage and Transportation



- ◆ Store and transport this equipment based on the storage and transportation requirements for humidity and temperature.
- ◆ Avoid transporting the equipment in environments such as water splashing, rain, direct sunlight, strong electric field, strong magnetic field, and strong vibration.
- ◆ Avoid storing this equipment for more than three months. Long-term storage requires stricter protection and necessary inspections.
- ◆ Pack the equipment strictly before transportation. Use a sealed box for long-distance transportation.
- ◆ Never transport this equipment with other equipment or materials that may harm or have negative impacts on this equipment.



- ◆ Use professional loading and unloading equipment to carry large-scale or heavy equipment.
- ◆ When carrying this equipment with bare hands, hold the equipment casing firmly with care to prevent parts falling. Failure to comply may result in personal injuries.
- ◆ Handle the equipment with care during transportation and mind your step to prevent personal injuries or equipment damage.
- ◆ Never stand or stay below the equipment when the equipment is lifted by hoisting equipment.

#### Installation



- ◆ Thoroughly read the safety instructions and user guide before installation.
- ◆ Do not modify this equipment.
- ◆ Do not loosen fixed bolts (especially those marked in red) on equipment components.
- ◆ Do not install this equipment in places with strong electric or magnetic fields.
- ◆ When this equipment is installed in a cabinet or final equipment, protection measures such as a fireproof enclosure, electrical enclosure, or mechanical enclosure must be provided. The IP rating must meet IEC standards and local laws and regulations.



- ◆ Equipment installation, wiring, maintenance, inspection, or parts replacement must be performed only by professionals.
- ◆ Installation, wiring, maintenance, inspection, or parts replacement must be performed only by experienced personnel who have been trained with necessary electrical information.
- ◆ Installation personnel must be familiar with equipment installation requirements and relevant technical materials.
- ◆ Before installing equipment with strong electromagnetic interference, such as a transformer, install an electromagnetic shielding device for this equipment to prevent malfunctions.

### Wiring



- ◆ Equipment installation, wiring, maintenance, inspection, or parts replacement must be performed only by professionals.
- ◆ Never perform wiring at power-on. Failure to comply will result in an electric shock.
- ◆ Before wiring, cut off all equipment power supplies. Wait at least 10 minutes before further operations because residual voltage exists after power-off.
- ◆ Make sure that the equipment is well grounded. Failure to comply will result in an electric shock.
- ◆ During wiring, follow the proper electrostatic discharge (ESD) procedures, and wear an antistatic wrist strap. Failure to comply will result in damage to internal equipment circuits.



- ◆ Never connect the power cable to output terminals of the equipment. Failure to comply may cause equipment damage or even a fire.
- ◆ When connecting a drive with the motor, make sure that the phase sequences of the drive and motor terminals are consistent to prevent reverse motor rotation.
- ◆ Wiring cables must meet diameter and shielding requirements. The shielding layer of the shielded cable must be reliably grounded at one end.
- ◆ After wiring, make sure that no screws are fallen and cables are exposed in the equipment.

## Power-on

**DANGER**

- ◆ Before power-on, make sure that the equipment is installed properly with reliable wiring and the motor can be restarted.
- ◆ Before power-on, make sure that the power supply meets equipment requirements to prevent equipment damage or even a fire.
- ◆ At power-on, unexpected operations may be triggered on the equipment. Therefore, stay away from the equipment.
- ◆ After power-on, do not open the cabinet door and protective cover of the equipment. Failure to comply will result in an electric shock.
- ◆ Do not touch any wiring terminals at power-on. Failure to comply will result in an electric shock.
- ◆ Do not remove any part of the equipment at power-on. Failure to comply will result in an electric shock.

## Operation

**DANGER**

- ◆ Do not touch any wiring terminals during operation. Failure to comply will result in an electric shock.
- ◆ Do not remove any part of the equipment during operation. Failure to comply will result in an electric shock.
- ◆ Do not touch the equipment shell, fan, or resistor for temperature detection. Failure to comply will result in heat injuries.
- ◆ Signal detection must be performed only by professionals during operation. Failure to comply will result in personal injuries or equipment damage.

**WARNING**

- ◆ Prevent metal or other objects from falling into the device during operation. Failure to comply may result in equipment damage.
- ◆ Do not start or stop the equipment using the contactor. Failure to comply may result in equipment damage.

## Maintenance

**DANGER**

- ◆ Equipment installation, wiring, maintenance, inspection, or parts replacement must be performed only by professionals.
- ◆ Do not maintain the equipment at power-on. Failure to comply will result in an electric shock.
- ◆ Before maintenance, cut off all equipment power supplies and wait at least 10 minutes.



- ◆ Perform daily and periodic inspection and maintenance for the equipment according to maintenance requirements and keep a maintenance record.

Repair



- ◆ Equipment installation, wiring, maintenance, inspection, or parts replacement must be performed only by professionals.
- ◆ Do not repair the equipment at power-on. Failure to comply will result in an electric shock.
- ◆ Before inspection and repair, cut off all equipment power supplies and wait at least 10 minutes.



- ◆ Require for repair services according to the product warranty agreement.
- ◆ When the equipment is faulty or damaged, require professionals to perform troubleshooting and repair by following repair instructions and keep a repair record.
- ◆ Replace quick-wear parts of the equipment according to the replacement guide.
- ◆ Do not operate damaged equipment. Failure to comply may result in worse damage.
- ◆ After the equipment is replaced, perform wiring inspection and parameter settings again.

Disposal



- ◆ Dispose of retired equipment by following local regulations or standards. Failure to comply may result in property damage, personal injuries, or even death.
- ◆ Recycle retired equipment by following industry waste disposal standards to avoid environmental pollution.

## Safety Signs

- Description of safety signs in the user guide



Read the user guide before installation and operation.



Reliably ground the system and equipment.



Danger!



High temperature!



Prevent personal injuries caused by machines.



High voltage!



Wait xx minutes before further operations.

- Description of safety signs on the equipment

For safe equipment operation and maintenance, comply with safety signs on the equipment, and do not damage or remove the safety labels. The following table describes the safety signs.

Safety Sign	Description
	<ul style="list-style-type: none"> <li>◆ Read the user guide before installation and operation. Failure to comply will result in an electric shock.</li> <li>◆ Do not remove the cover at power-on or within 10 minutes after power-off.</li> <li>◆ Before maintenance, inspection, and wiring, cut off input and output power, and wait at least 10 minutes until the power indicator is off.</li> </ul>



# Contents

Revision History .....	1
Safety Instructions .....	2
Safety Precautions.....	2
Safety Levels and Definitions .....	2
Safety Instructions.....	2
Safety Signs.....	7
1 Product Overview.....	10
1.1 Product Information.....	10
1.2 Panel Operations .....	11
2 Installation and Wiring.....	12
2.1 Installation .....	12
2.1.1 Layout in the Cabinet .....	12
2.1.2 Installation Method.....	13
2.1.2 Installation Environment .....	14
2.2 Wiring.....	15
2.2.1 Wiring Diagrams .....	15
2.2.2 Terminal Specifications .....	17
2.2.3 Wiring of Control Signal Input Terminals.....	18
3 Parameters.....	22
3.1 Parameter Table.....	22
3.2 Industry Macro Instructions.....	62
3.3 Communication Addresses.....	64
4 Troubleshooting .....	68
4.1 Fault Codes and Solutions .....	68
4.2 Symptoms and Solutions.....	72
5 Technical Data and Model Selection.....	74
5.1 Overall Dimensions.....	74
5.2 Technical Data.....	74
5.2.1 Rated Data.....	74
5.2.2 Technical Specifications .....	76
5.3 Selection of Electrical Peripherals.....	78
5.4 Selection of the EMC Filter .....	78
5.4.1 Internal (Built-in) EMC Filter .....	78

---

5.4.2 External Filter .....	78
5.5 Selection of the AC Input Reactor.....	82
5.6 Selection of the dv/dt Output Reactor .....	82
5.7 Selection of Cables and Tightening Torque.....	84
5.8 Selection of Optionals .....	85

# 1 Product Overview

Thank you for purchasing the MD200 series AC drive developed by Inovance.

With the compact booksize structure design, the MD200 series AC drive allows seamless parallel installation and guide rail installation, featuring small size and simplified installation. The wiring terminals are uncovered, simplifying wiring, operation, and maintenance. The input filter is built-in for all series to enhance the anti-jamming ability and reduce external interference. Typical applications can be realized using the macro parameters.

## 1.1 Product Information

Introduction to the operating panel

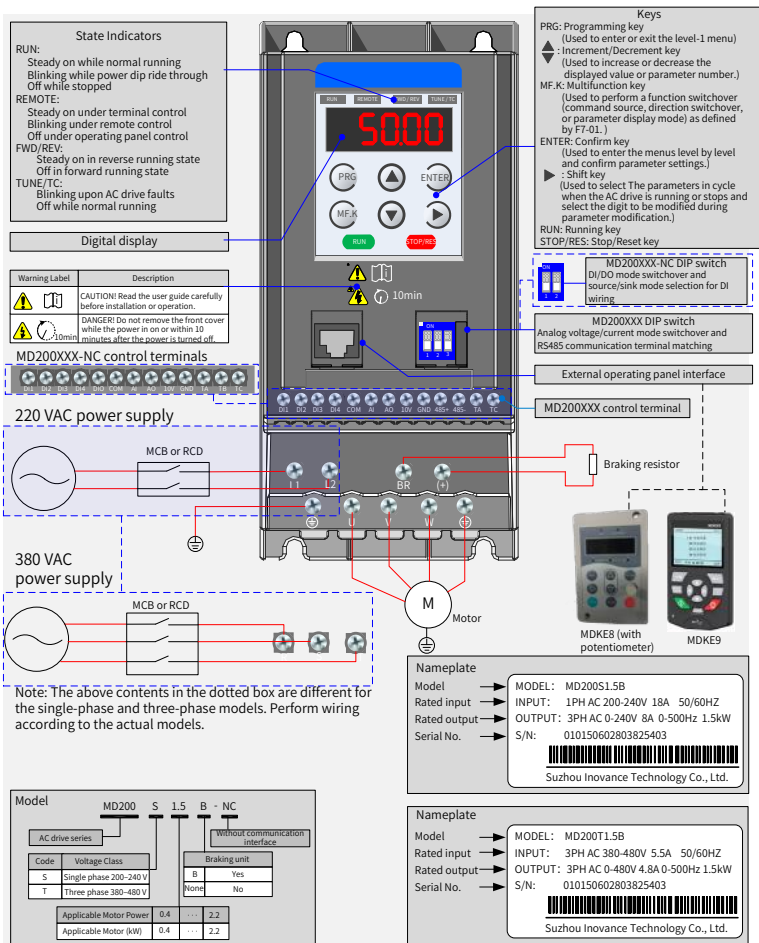

## 1.2 Panel Operations

Quick commissioning flowchart:

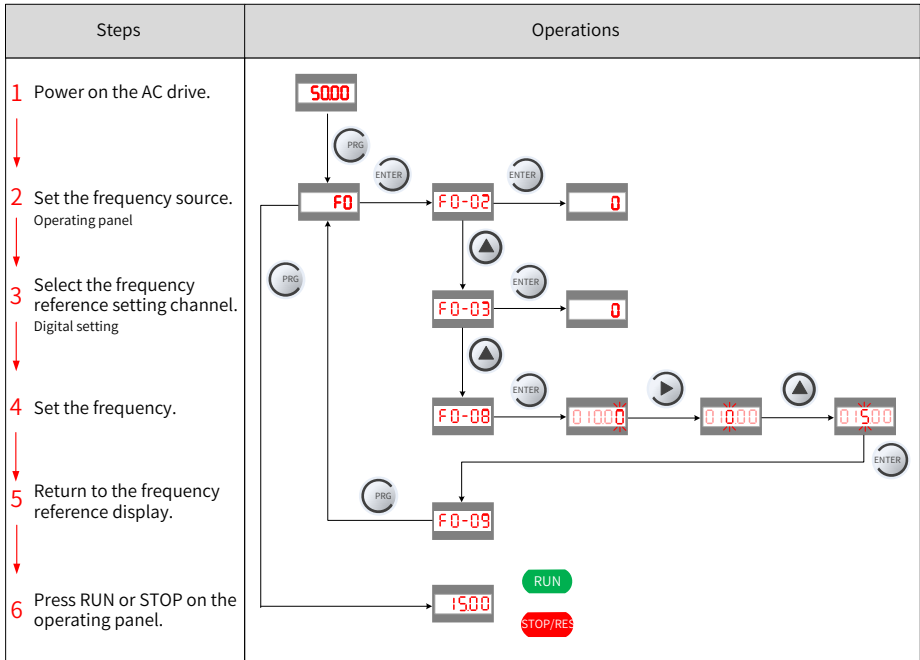

Quick parameter viewing flowchart:

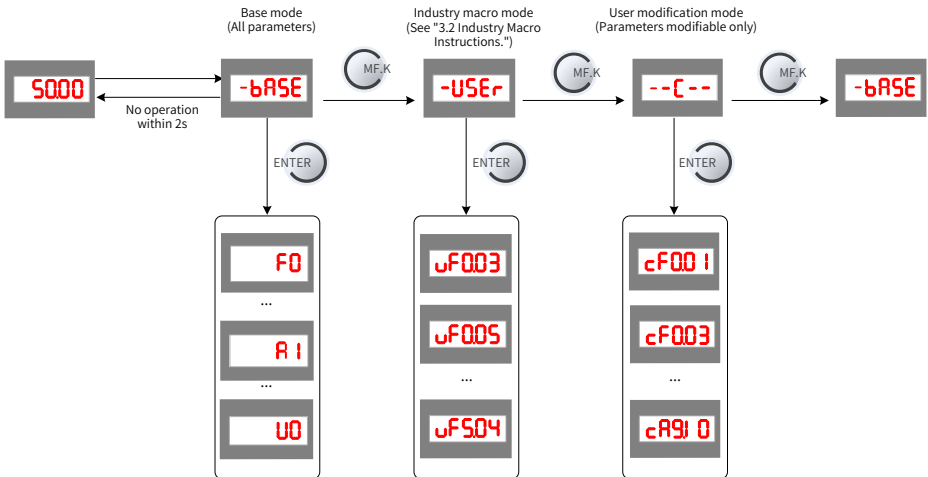

## 2 Installation and Wiring

### 2.1 Installation

The AC drive must be installed in a fireproof cabinet with doors that provide effective electrical and mechanical protection. The installation must conform to local and regional laws and regulations, and relevant IEC requirements.

#### 2.1.1 Layout in the Cabinet

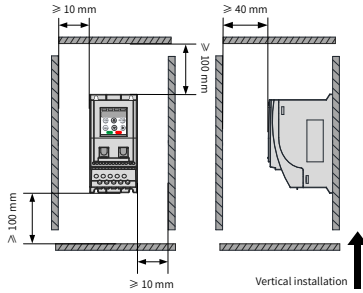

Installing a single AC drive

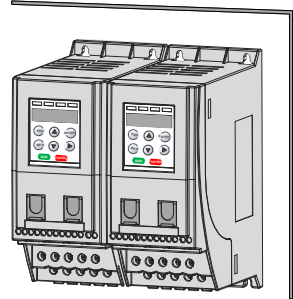

Installing two AC drives in parallel

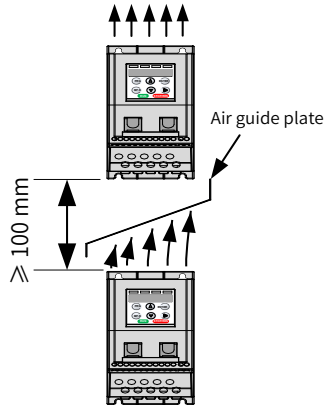

Installing one AC drive above another

## 2.1.2 Installation Method

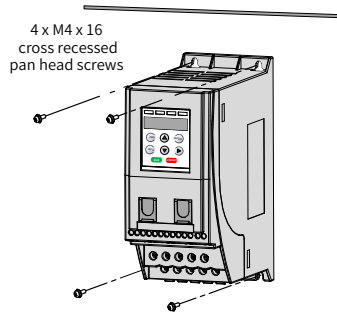

With screws

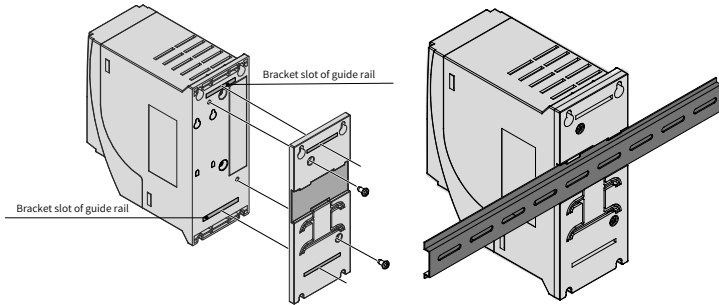

With a guide rail



### NOTE

- ◆ To install the AC drive with screws, all the four screws must be tightened.
- ◆ To install the AC drive with a guide rail, order the DIN guide rail (optional) by referring to ["5.8 Selection of Optionals"](#).

### 2.1.2 Installation Environment

- 1) Ambient temperature: The AC drive's service life is greatly influenced by the ambient temperature. Do not run the AC drive under a temperature exceeding the allowed temperature range (-10°C to +50°C ).
- 2) Install the AC drive on a flame-retardant surface, and ensure that sufficient space is left around the enclosure to allow for efficient heat dissipation. The AC drive generates significant heat during working. Use screws to install the AC drive on the mounting bracket vertically.
- 3) Install the AC drive at a place away from vibration. The vibration shall not exceed 0.6 G. Keep away from devices such as punch presses.
- 4) Avoid direct sunlight exposure, moisture, and water drop.
- 5) Ensure that the mounting location is protected against corrosive, combustible, and explosive gases.
- 6) Ensure that the mounting location is free from oil and dust.

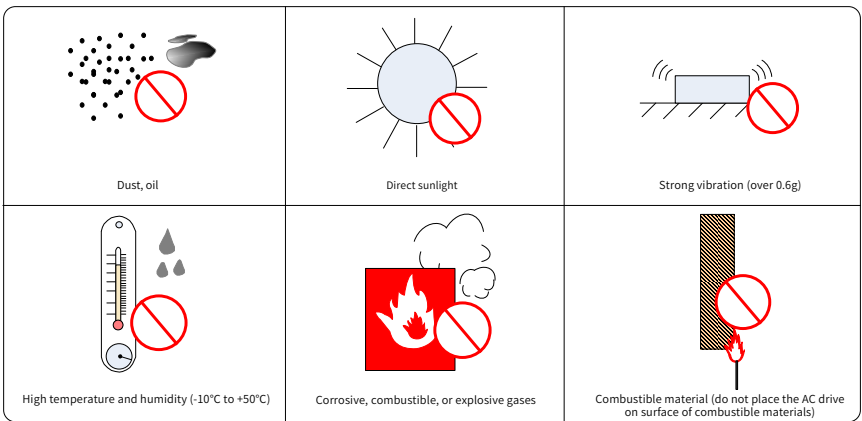

Figure 2-1 Installation environment requirements

## 2.2 Wiring

### 2.2.1 Wiring Diagrams

■ MD200XXX wiring diagram

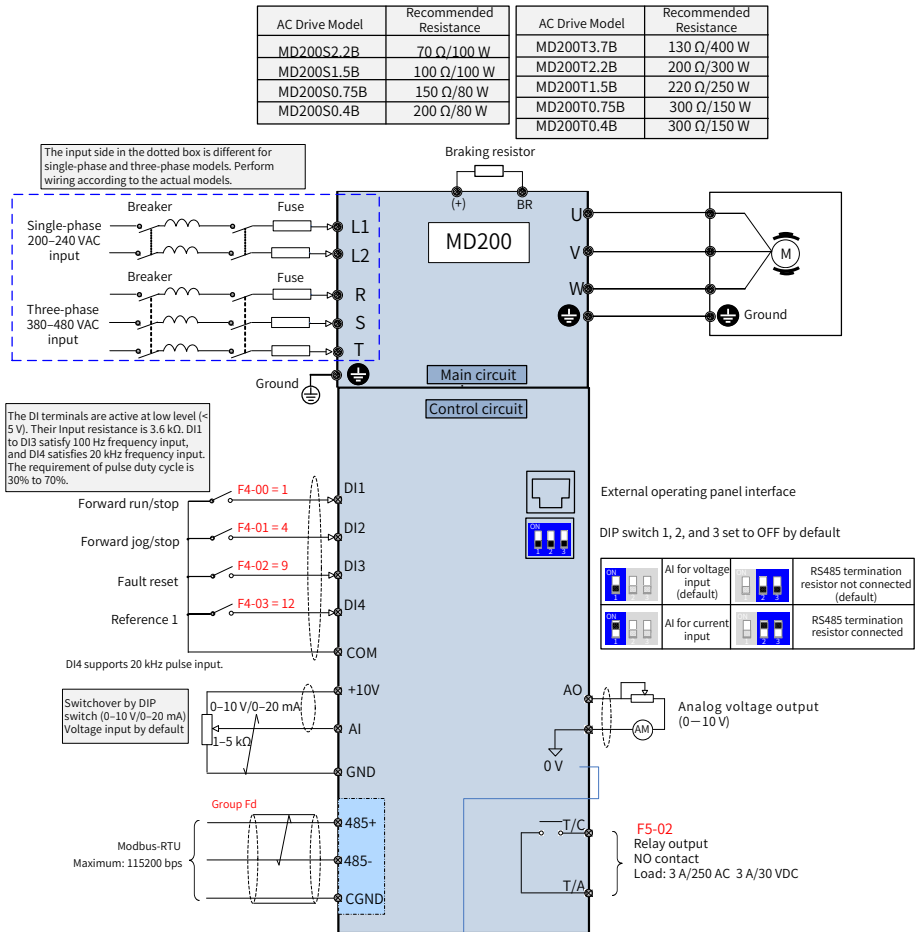

Figure 2-2 Wiring diagram of the single-phase/three-phase (MD200S0.4B to MD200S2.2B and MD200T0.4B to MD200T3.7B) power input terminals



■ MD200XXX-NC wiring diagram

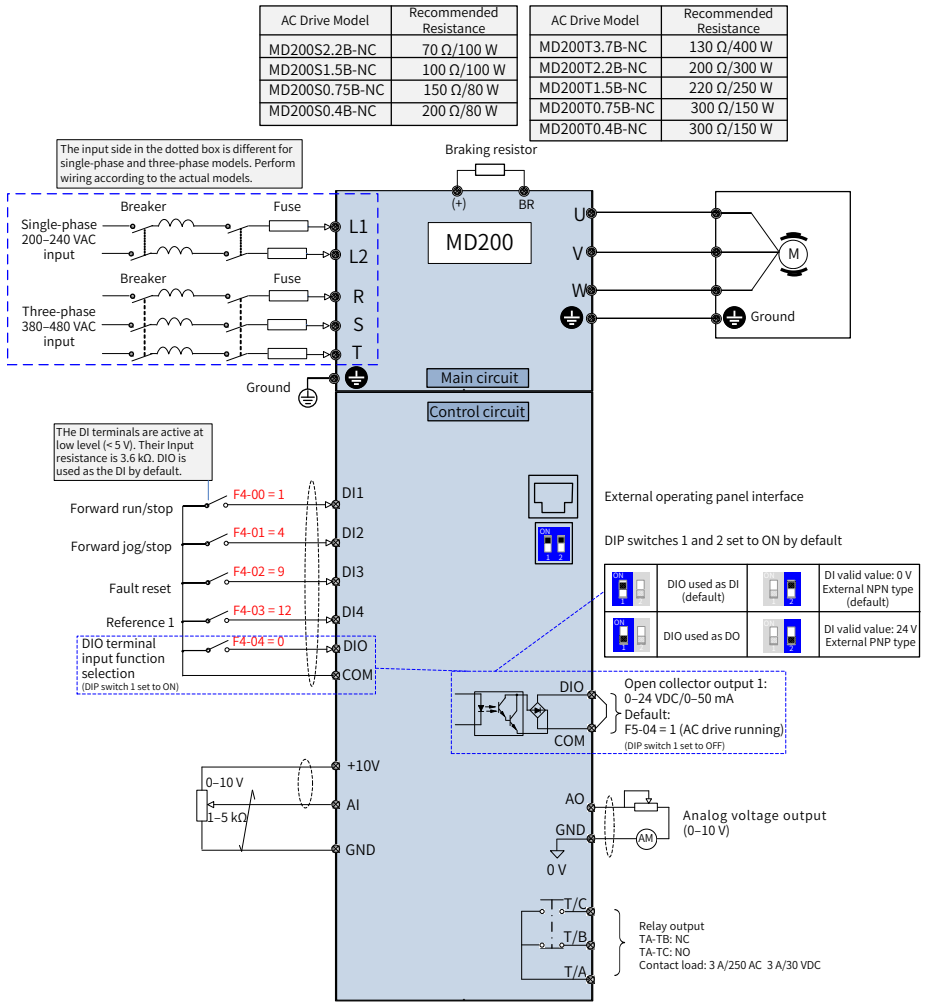

Figure 2-3 Wiring diagram of the single-phase/three-phase (MD200S0.4B-NC to MD200S2.2B-NC and MD200T0.4B-NC to MD200T3.7B-NC) power input terminals

- ◆ Noise interference may cause malfunctions. Therefore, keep the signal cable at least 10 cm away from the power cable and separately configure the input and output sides of the main circuit.
- ◆ Do not leave cuttings inside the AC drive while wiring. The cuttings may cause abnormalities, faults, or malfunctions.
- ◆ Keep the AC drive clean. Do not drop cuttings and dust into the AC drive while drilling mounting holes on the control cabinet.



## 2.2.2 Terminal Specifications

Terminal Type	Terminal Mark	Terminal Name	Terminal Function	
Main circuit	L1, L2	Single-phase power supply input	Connected to the power supply. L1 is connected to the live wire and L2 is connected to the neutral wire.	
	R, S, T	Three-phase power supply input	Connected to the power supply.	
	U, V, W	AC drive output	Connected to the motor.	
	BR, (+)	Braking resistor connection	Connect to the braking resistor.	
	⊕	Grounding terminal	Connected to the ground.	
Control circuit	DI1–DI4	Digital input	Multi-functional input terminals	Low level effective (valid level < 5 V) DI1 to DI3 are low-speed Dis for frequency less than 100 Hz. DI4 is used for high-speed pulse input for frequency up to 20 kHz.
	DIO	DI/DO	Multi-functional DI/DO terminals	The DI or DO function is selected by using the DIP switch. See Figure 2-2 for details. The DO common terminal is COM.
	COM	24V power ground	Internal 24 V ground	Internally isolated from GND.
	+10V	AI/AO	10 V analog voltage output	10 V ± 10%, maximum of 10 mA
	GND		Analog ground	Internally isolated from COM.
	AI		Analog single-end input channel 1	(0–10 V)/(0–20 mA) input; 12-bit resolution; calibration accuracy of 0.5%; response time < 8 ms
	AO		AO1	AO: 0–10 V; accuracy of 100 mV; 10-bit resolution; accuracy of 1%
	TA-TC, TA-TB	Relay output	Relay output	TA-TC: normally open (NO); TA-TB: normally closed (NC) Contact load: 3 A/250 AC, 3 A/30 VDC Note: TA-TB is only used for MD200XXX-NC.

Terminal Type	Terminal Mark	Terminal Name	Terminal Function	
Control circuit	GND	Communication	Common ground with 10 V	Half duplex RS485 communication, with the highest baud rate of 115200 for up to 64 nodes Note: The RS485 communication function is only be used for MD200XXX.
	485+		RS485 positive communication signal	
	485-		RS485 negative communication signal	

### 2.2.3 Wiring of Control Signal Input Terminals

■ AI terminals

Weak analog voltage signals are prone to suffer external interference. Therefore, the shielded cable must be used and the cable length must be less than 20 m, as shown in Figure 2-4. In applications where the analog signal suffers severe interference, install a filter capacitor or ferrite core at the analog signal source, as shown in Figure 2-5.

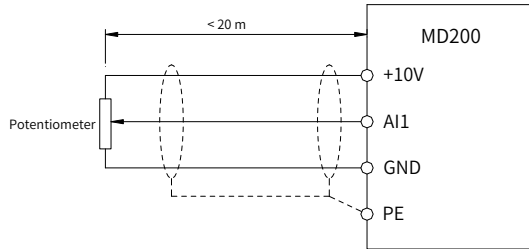

Figure 2-4 Wiring of AI terminals

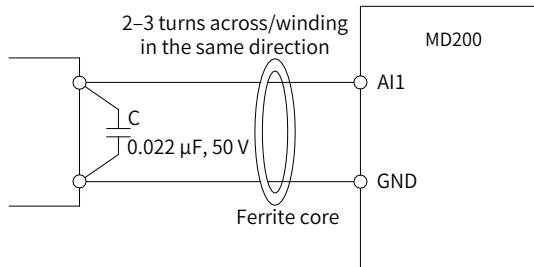

Figure 2-5 Installing a ferrite core

■ DI terminals

Generally, use the shielded cable not longer than 20 m. When active driving is adopted, necessary filtering measures shall be taken to prevent interference to the power supply. The contact control mode is recommended.

## ■ Sink wiring method

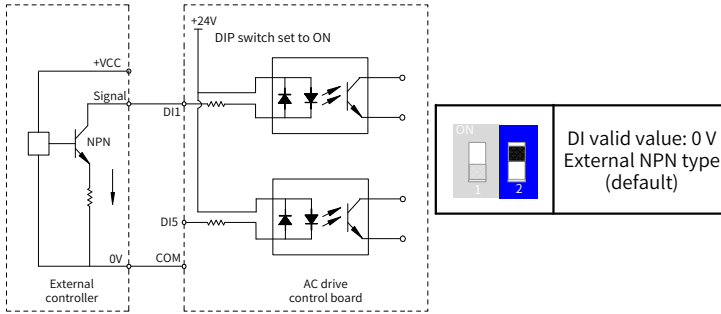

Figure 2-6 Sink wiring

In such wiring mode, the DI terminals of different AC drives cannot be connected in parallel. Otherwise, DI malfunctions may be caused. If parallel connection (different AC drives) is required, connect a diode in series (anode connected to the DI) at the DI, as shown in the following figure. The diode needs to satisfy the requirements:  $I_F > 10 \text{ mA}$ ,  $U_F < 1 \text{ V}$ .

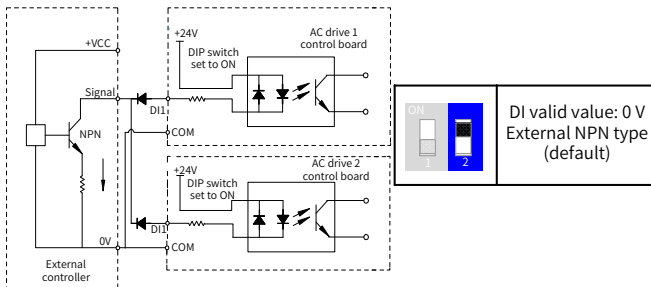

Figure 2-7 Parallel connection of DI terminals (multiple AC drives) in sink mode

■ Source wiring method

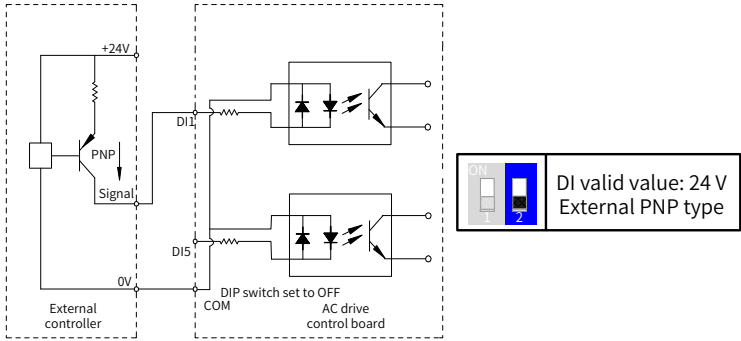

Figure 2-8 Source wiring

■ DO terminals

When the DO terminal needs to drive the relay, a snubber diode shall be installed on both sides of the relay coil. Otherwise, it may cause damage to the 24 VDC power supply. The driving capacity is not more than 50 mA.

Do not reverse the polarity of the absorption diode during installation, as shown in the following figure. Otherwise, the 24 VDC power supply will be damaged immediately when the DO terminal works.

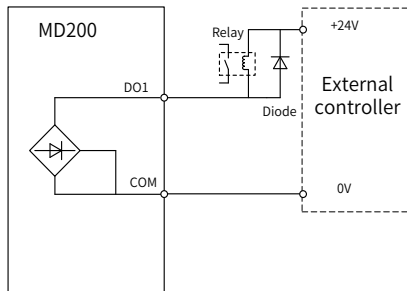

Figure 2-9 Wiring of DO terminals

The inductive load (relay, contactor, and motor) causes voltage spike after the current is removed. A voltage dependent resistor (VDR) must be used for protection at the relay contact and absorption circuits such as VDRs, RC absorption circuits and diodes must be installed on inductive loads to ensure minimum interference during cutoff.

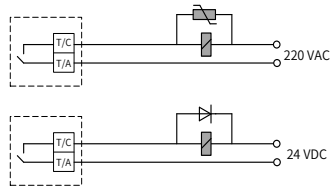

Figure 2-10 Anti-interference processing of relay output terminals



## NOTE

- ◆ Wiring tools: Phillips head screwdriver or straight screwdriver; main circuit terminal screw  $\geq$  M4; control circuit terminal  $\geq$  M3
- ◆ It is recommended that L1 be connected with the live wire and L2 be connected with the neutral wire. The output cables and PE shall be wired in priority.
- ◆ For control terminals,  $0.3 \text{ mm}^2$  to  $0.75 \text{ mm}^2$  cables can be used.
- ◆ The contact leakage current of the AC drive is greater than 3.5 mA. Therefore, the AC drive must be well grounded. Otherwise, electric shocks will be caused.
- ◆ Use a screwdriver or other tools to set the DIP switch rather than using fingers.
- ◆ If the AC drive is used in an IT power system (with neutral ungrounded), the ground jumper (on the left of the AC drive) of the VDR must be removed.

Remove the ground jumper (on the left of the AC drive) of the safety capacitor (EMC) when the AC drive is used in the following cases. The locations of the ground jumpers of the VDR and EMC are shown in the following figure.

- 1) The AC drive is not grounded, and the bottom heatsink is in direct contact with the metal cabinet (which may cause electric shocks easily).
- 2) The residual current device trips upon startup after it is installed.

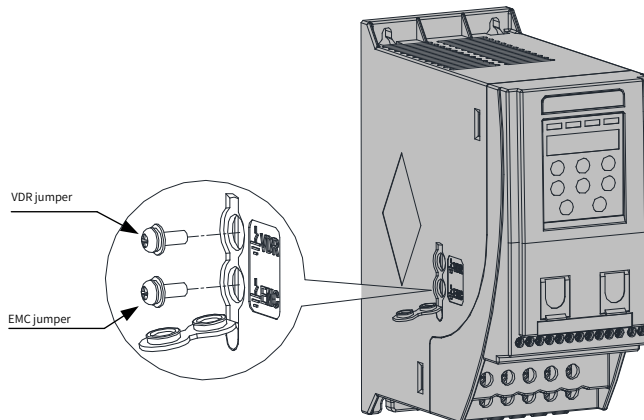

Figure 2-11 Locations of ground jumpers of the VDR and EMC

## 3 Parameters

### 3.1 Parameter Table

If FP-00 is set to a non-zero value (which enables password protection), the parameter menu is accessible in base mode and modification mode only after the correct password is entered. To disable password protection, set FP-00 to 0.

Groups F and A include standard function parameters. Group U includes the monitoring function parameters.

Description of the communication address:

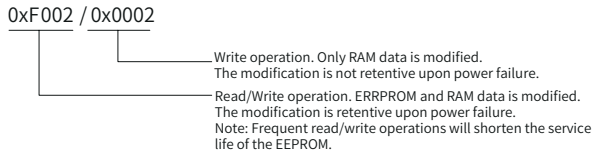

Param. No.	Param. Name	Setting Range	Default	Communication Address
Group F0: Standard Parameters				
F0-01	Control mode	0: SVC 2: V/f control	2	0xF001/0x0001
F0-02	Command source selection	0: Operating panel control (indicator OFF) 1: Terminal I/O control (indicator ON) 2: Communication control (indicator blinking)	0	0xF002/0x0002
F0-03	Main frequency source X selection	0: Digital setting (initial value F0-08 can be modified by operating panel or terminal Up/Down, non-retentive at power failure) 1: Digital setting (initial value F0-08 can be modified by operating panel or terminal Up/Down, retentive at power failure) 2: AI 3: External operating panel potentiometer 5: Pulse reference (DI4) 6: Multi-reference 7: Simple PLC 8: PID 9: Communication setting	0	0xF003/0x0003
F0-04	Auxiliary frequency reference selection	Same as F0-03 (Main frequency source X selection)	0	0xF004/0x0004

Param. No.	Param. Name	Setting Range		Default	Communication Address
F0-05	Base value of range of auxiliary frequency reference for main and auxiliary superposition	0: Relative to the maximum frequency 1: Relative to main frequency reference X		0	0xF005/0x0005
F0-06	Range of auxiliary frequency reference for main and auxiliary superposition	0% to 150%		100%	0xF006/0x0006
F0-07	Final frequency reference setting selection	Ones position: Frequency reference selection 0: Main frequency reference X 1: Main and auxiliary calculation result (determined by the tens position) 2: Switchover between main frequency reference X and auxiliary frequency reference Y 3: Switchover between main frequency reference X and main and auxiliary calculation result 4: Switchover between auxiliary frequency reference Y and main and auxiliary calculation result Tens position: Main and auxiliary calculation relationship 0: Main + Auxiliary 1: Main - Auxiliary 2: Max. (main, auxiliary) 3: Min. (main, auxiliary)		00	0xF007/0x0007
F0-08	Preset frequency	0.00 Hz to F0-10 (Maximum frequency)		50.00 Hz	0xF008/0x0008
F0-09	Running direction	0: Run in the same direction 1: Run in the reverse direction		0	0xF009/0x0009
F0-10	Maximum frequency	50.00 Hz to 500.00 Hz		50.00 Hz	0xF00A/0x000A
F0-11	Upper limit frequency source	0: Set by F0-12 (Frequency upper limit) 1: AI 2: External operating panel potentiometer	4: Pulse reference 5: Communication setting	0	0xF00B/0x000B
F0-12	Frequency upper limit	F0-14 (Frequency lower limit) to F0-10 (Maximum frequency)		50.00 Hz	0xF00C/0x000C
F0-14	Frequency lower limit	0.00 Hz to F0-12 (Frequency upper limit)		0.00 Hz	0xF00E/0x000E



### 3 Parameters

Param. No.	Param. Name	Setting Range	Default	Communication Address
F0-15	Carrier frequency	0.8 kHz to 12.0 kHz	Model dependent	0xF00F/0x000F
F0-16	Carrier frequency adjusted with temperature	0: No 1: Yes	1	0xF010/0x0010
F0-17	Acceleration time 1	0.00s to 650.00s (F0-19 = 2) 0.0s to 6500.0s (F0-19 = 1) 0s to 65000s (F0-19 = 0)	20.0s	0xF011/0x0011
F0-18	Deceleration time 1	0.00s to 650.00s (F0-19 = 2) 0.0s to 6500.0s (F0-19 = 1) 0s to 65000s (F0-19 = 0)	20.0s	0xF012/0x0012
F0-19	Acceleration/Deceleration time unit	0: 1s 1: 0.1s 2: 0.01s	1	0xF012/0x0013
F0-23	Retentive of digital setting frequency upon stop	0: Disabled 1: Enabled	0	0xF017/0x0017
F0-25	Acceleration/Deceleration time base frequency	0: F0-10 (Maximum frequency) 1: Frequency reference 2: 100 Hz	0	0xF019/0x0019
F0-26	Base frequency for UP/DOWN modification during running	0: Running frequency 1: Frequency reference	0	0xF01A/0x001A
<b>Group F1: Motor 1 Vector Control Parameters</b>				
F1-01	Rated motor power	0.1 kW to 5.5 kW	Model dependent	0xF101/0x0101
F1-02	Rated motor voltage	1 V to 600 V	Model dependent	0xF102/0x0102
F1-03	Rated motor current	0.01 A to 30.00 A	Model dependent	0xF103/0x0103
F1-04	Rated motor frequency	0.01 Hz to maximum frequency	Model dependent	0xF104/0x0104
F1-05	Rated motor speed	1 rpm to 65535 rpm	Model dependent	0xF105/0x0105
F1-06	Asynchronous motor stator resistance	0.001 $\Omega$ to 65.535 $\Omega$	Auto-tuning parameter	0xF106/0x0106
F1-07	Asynchronous motor rotor resistance	0.001 $\Omega$ to 65.535 $\Omega$	Auto-tuning parameter	0xF107/0x0107
F1-08	Asynchronous motor leakage inductive reactance	0.001 mH to 65.535 mH	Auto-tuning parameter	0xF108/0x0108
F1-09	Asynchronous motor mutual inductive reactance	0.001 mH to 65.535 mH	Auto-tuning parameter	0xF109/0x0109

Param. No.	Param. Name	Setting Range	Default	Communication Address
F1-10	Asynchronous motor no-load current	0.01 A to F1-03 (AC drive power $\leq$ 55 kW) 0.1 A to F1-03 (AC drive power > 55 kW)	Auto-tuning parameter	0xF10A/0x010A
F1-37	Auto-tuning selection	0: No operation 1: Asynchronous motor static auto-tuning 1 2: Asynchronous motor dynamic auto-tuning	0	0xF125/0x0125
Group F2: Vector Control Parameters				
F2-00	Speed loop proportional gain 1	1 to 100	30	0xF200/0x0200
F2-01	Speed loop integral time 1	0.01s to 10.00s	0.50s	0xF201/0x0201
F2-02	Switchover frequency 1	0.00 to F2-05 (Switchover frequency 2)	5.00 Hz	0xF202/0x0202
F2-03	Speed loop proportional gain 2	1 to 100	20	0xF203/0x0203
F2-04	Speed loop integral time 2	0.01s to 10.00s	1.00s	0xF204/0x0204
F2-05	Switchover frequency 2	F2-02 (Switchover frequency 1) to maximum frequency	10.00 Hz	0xF205/0x0205
F2-06	Vector control slip gain	50% to 200%	100%	0xF206/0x0206
F2-07	Speed feedback filter time in SVC mode	0.000s to 1.000s	0.050s	0xF207/0x0207
F2-08	Vector control overexcitation gain	0 to 200	0	0xF208/0x0208
F2-09	Torque limit source in speed control	0: Set by F2-10 (Digital setting of torque limit in speed control) 1: AI 2: External operating panel potentiometer 4: Pulse reference 5: Communication setting 6: Min. ( AI ,  External operating panel potentiometer ) 7: Max. ( AI ,  External operating panel potentiometer ) 100% of the values 1 to 7 corresponding to F2-10	0	0xF209/0x0209
F2-10	Digital setting of torque limit in speed control	0.0% to 200.0%	150.0%	0xF20A/0x020A

### 3 Parameters

Param. No.	Param. Name	Setting Range	Default	Communication Address
F2-11	Torque limit source in speed control (in regenerative state)	0: Set by F2-09 (Torque limit source in speed control) and F2-10 (Digital setting of torque limit in speed control) 1: AI 2: External operating panel potentiometer 4: Pulse reference 5: Communication setting 6: Min. ( AI ,  External operating panel potentiometer ) 7: Max. ( AI ,  External operating panel potentiometer ) 8: Set by F2-12 [Digital setting of torque limit in speed control (regenerative)] 100% of the values 1 to 7 corresponding to F2-12	0	0xF20B/0x020B
F2-12	Digital setting of torque limit in speed control (in regenerative state)	0.0% to 200.0%	150.0%	0xF20C/0x020C
F2-13	Excitation adjustment proportional gain	0 to 60000	10	0xF20D/0x020D
F2-14	Excitation adjustment integral gain	0 to 60000	10	0xF20E/0x020E
F2-15	Torque adjustment proportional gain	0 to 60000	10	0xF20F/0x020F
F2-16	Torque adjustment integral gain	0 to 60000	10	0xF210/0x0210
F2-17	Speed loop attribute	Ones position: Integral separation 0: Disabled 1: Enabled Tens position: Torque feedforward 0: Disabled 1: Enabled	00	0xF211/0x0211
F2-18	Torque feedforward gain	20 to 100	80	0xF212/0x0212
F2-19	Torque feedforward filter time	10 to 200	50	0xF213/0x0213
F2-21	Maximum torque coefficient in field weakening area	50% to 200%	80%	0xF215/0x0215
F2-22	Regenerative power upper limit	0.0%: No limit 0.1% to 200.0%	0.0%	0xF216/0x0216

Param. No.	Param. Name	Setting Range	Default	Communication Address
Group F3: V/f Control Parameters				
F3-00	V/f curve setting	0: Linear V/f 1: Multi-point V/f 10: V/f complete separation mode 11: V/f half separation	0	0xF300/0x0300
F3-01	Torque boost	0.0%: Automatic torque boost 0.1% to 30.0%	0.0%	0xF301/0x0301
F3-02	Cutoff frequency of torque boost	0.00 Hz to maximum frequency	50.00 Hz	0xF302/0x0302
F3-03	Multi-point V/f frequency 1	0.00 Hz to F3-05 (Multi-point V/f frequency 2)	0.00 Hz	0xF303/0x0303
F3-04	Multi-point V/f voltage 1	0.0% to 100.0%	0.0%	0xF304/0x0304
F3-05	Multi-point V/f frequency 2	F3-03 (Multi-point V/f frequency 1) to F3-07 (Multi-point V/f frequency 3)	0.00 Hz	0xF305/0x0305
F3-06	Multi-point V/f voltage 2	0.0% to 100.0%	0.0%	0xF306/0x0306
F3-07	Multi-point V/f frequency 3	F3-05 (Multi-point V/f frequency 2) to F1-04 (Rated motor frequency)	0.00 Hz	0xF307/0x0307
F3-08	Multi-point V/f voltage 3	0.0% to 100.0%	0.0%	0xF308/0x0308
F3-09	V/f slip compensation gain	0.0% to 200.0%	0.0%	0xF309/0x0309
F3-10	V/f over-excitation gain	0 to 200	64	0xF30A/0x030A
F3-13	Voltage source for V/F separation	0: Set by F3-14 (Voltage digital setting for V/f separation) 1: AI 2: External operating panel potentiometer 4: Pulse reference (DI4) 5: Multi-reference 6: Simple PLC 7: PID 8: Communication setting Note: 100.0% corresponds to the rated motor voltage.	0	0xF30D/0x030D
F3-14	Voltage digital setting for V/f separation	0 V to rated motor voltage	0 V	0xF30E/0x030E
F3-15	Voltage rise time of V/f separation	0.0s to 1000.0s Note: It sets the time for the output voltage to rise from 0 to the rated motor voltage.	0.0s	0xF30F/0x030F
F3-16	Voltage decline time of V/f separation	0.0s to 1000.0s Note: It sets the time for the output voltage to decline from the rated motor voltage to 0.	0.0s	0xF310/0x0310

### 3 Parameters

Param. No.	Param. Name	Setting Range	Default	Communication Address
F3-17	Stop mode selection for V/f separation	0: Frequency and voltage declining to 0 independently 1: Frequency declining after voltage declines to 0	0	0xF311/0x0311
F3-18	Current limit level	50% to 200%	150%	0xF312/0x0312
F3-19	Current limit selection	0: Disabled 1: Enabled	1	0xF313/0x0313
F3-20	Current limit gain	0 to 100	20	0xF314/0x0314
F3-21	Compensation factor of speed multiplying current limit level	0 to 200%	50%	0xF315/0x0315

In high frequency area, the motor drive current is low. If the frequency is lower than the rated frequency, greater motor speed dip will be caused at the same current limit level. To improve motor running performance, you can lower the current limit level when the frequency is higher than the rated frequency. This helps to improve the acceleration performance in the applications, such as centrifuges, where high running frequency and several times of field weakening are required, and the load inertia is large.

$$\text{Current limit level above rated frequency} = (f_s/f_n) \times k \times \text{LimitCur}$$

$f_s$ : running frequency;  $f_n$ : rated motor frequency;  $k$ : compensation factor of speed multiplying current limit level (F3-21); LimitCur: current limit level (F3-18)

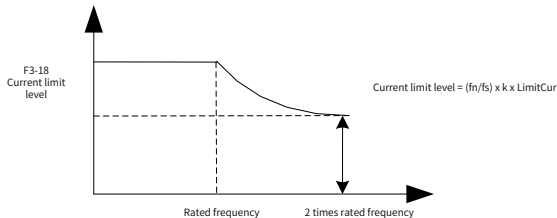

Speed multiplying current limit level

Note:

150% of the current limit level corresponds to 1.5 times the rated current of the AC drive.

For high-power motors with carrier frequency below 2 kHz, the overcurrent fast prevention function is enabled in advance of the current limit function due to the increase of ripple current, which will result in insufficient torque output. In this case, the current limit level must be lowered.

F3-22	Voltage limit	330.0 V to 800.0 V	Single-phase: 390.0 V Three-phase: 760.0 V	0xF316/0x0316
F3-23	Voltage limit selection	0: Disabled 1: Enabled	1	0xF317/0x0317
F3-24	Frequency gain for voltage limit	0 to 100	50	0xF318/0x0318
F3-25	Voltage gain for voltage limit	0 to 100	30	0xF319/0x0319

Param. No.	Param. Name	Setting Range	Default	Communication Address
F3-26	Frequency rise threshold during voltage limit	0 to 50 Hz	5 Hz	0xF31A/0x031A

AC drive bus voltage limit (and braking resistor applied voltage settings)

When the bus voltage rises above the voltage limit 390 V, the motor becomes regenerative (motor speed > output frequency). This function prevents overvoltage trips by adjusting the output frequency to extend the deceleration time in this case. If the actual deceleration time cannot satisfy the requirement, increase the value of F3-10 (V/f over-excitation gain) adequately.

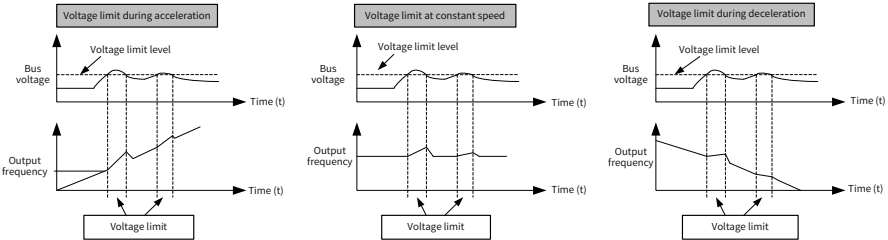

#### Overvoltage stall action

Note: When a braking resistor, braking unit, or energy feedback unit is used, set F3-23 (Voltage limit selection) to 0 (Disabled). Otherwise, the deceleration time may be prolonged.

F3-27	Slip compensation time constant	0.1s to 10.0s	0.5	0xF31B/0x031B
-------	---------------------------------	---------------	-----	---------------

The shorter the slip compensation response time is set, the quicker the response speed is.

3 Parameters

Param. No.	Param. Name	Setting Range	Default	Communication Address
<b>Group F4: Input Terminals</b>				
F4-00	DI1 function selection	0: No function 1: Forward RUN (FWD) or running command	1	0xF400/0x0400
F4-01	DI2 function selection	2: Reverse RUN (REV) or running direction (When these parameters are set to values 1 and 2, F4-11 must be set.)	4	0xF401/0x0401
F4-02	DI3 function selection	3: Three-wire control 4: Forward jog (FJOG) 5: Reverse jog (RJOG)	9	0xF402/0x0402
F4-03	DI4 function selection	6: Terminal UP 7: Terminal DOWN 8: Coast to stop	12	0xF403/0x0403
F4-04	DIO input function selection (only for MD200XXX-NC)	9: Fault reset (RESET) 10: Running pause 11: External fault normally open (NO) input 12: Multi-reference terminal 1 13: Multi-reference terminal 2 14: Multi-reference terminal 3 16: Terminal 1 for acceleration/deceleration time selection 17: Terminal 2 for acceleration/deceleration time selection 18: Frequency source switchover 19: UP and DOWN setting clear (terminal, operating panel) 20: Running command switchover terminal 21: Acceleration/Deceleration prohibited 22: PID pause 23: PLC status reset 24: Wobble pause 25: Counter input 26: Counter reset 27: Length counter input 28: Length counter reset 29: Torque control prohibited 30: Pulse frequency input (Note: For MD200XXX, this is valid for the DI4 terminal only. For MD200XXX-NC, this is valid for the DIO terminal only.) 31: Switched to FVC forcibly (reserved) 32: Immediate DC injection braking 33: External fault normally closed (NC) input 34: Frequency modification enabled 35: Reverse PID operation direction 36: External stop terminal 1 37: Command source switchover terminal 2 38: PID integral disabled 39: Switchover between main frequency reference X and preset frequency reference 40: Switchover between auxiliary frequency reference Y and preset frequency reference 41: Motor selection terminal 42: Reserved 43: PID parameter switchover 44: User-defined fault 1 45: User-defined fault 2 46: Speed control/Torque control switchover 47: Emergency stop 48: External stop terminal 2 49: Deceleration DC injection braking 50: Clear the current running time 51: Two-wire/Three-wire mode switchover 52: Reverse frequency forbidden	0	0xF404/0x0404
F4-10	DI filter time	0.000s to 1.000s	0.010s	0xF40A/0x040A

Param. No.	Param. Name	Setting Range	Default	Communication Address
F4-11	Terminal command mode	0: Two-wire mode 1 1: Two-wire mode 2 2: Three-wire mode 1 3: Three-wire mode 2	0	0xF40B/0x040B
F4-12	Terminal UP/DOWN change rate	0.001 Hz/s to 65.535 Hz/s	1.000 Hz/s	0xF40C/0x040C
F4-13	AI curve 1 minimum input	0.00 V to F4-15 (AI curve 1 maximum input)	0.00 V	0xF40D/0x040D
F4-14	Corresponding percentage of AI curve 1 minimum input	-100.0% to +100.0%	0.0%	0xF40E/0x040E
F4-15	AI curve 1 maximum input	F4-13 (AI curve 1 minimum input) to 10.00 V	10.00 V	0xF40F/0x040F
F4-16	Corresponding percentage of AI curve 1 maximum input	-100.0% to +100.0%	100.0%	0xF410/0x0410
F4-17	AI filter time	0.00s to 10.00s	0.10s	0xF411/0x0411
F4-18	AI curve 2 minimum input	0.00 V to F4-20 (AI curve 2 maximum input)	0.00 V	0xF412/0x0412
F4-19	Corresponding percentage of AI curve 2 minimum input	-100.0% to +100.0%	0.0%	0xF413/0x0413
F4-20	AI curve 2 maximum input	F4-18 (AI curve 2 minimum input) to 10.00 V	10.00 V	0xF414/0x0414
F4-21	Corresponding percentage of AI curve 2 maximum input	-100.0% to +100.0%	100.0%	0xF415/0x0415
F4-22	External operating panel potentiometer filter time	0.00s to 10.00s	0.10s	0xF416/0x0416
F4-28	Pulse minimum input	0.00 kHz to F4-30 (Pulse maximum input)	0.00 kHz	0xF41C/0x041C
F4-29	Corresponding percentage of pulse minimum input	-100.0% to +100.0%	0.0%	0xF41D/0x041D
F4-30	Pulse maximum input	F4-28 (Pulse minimum input) to 20.00 kHz	20.00 kHz	0xF41E/0x041E
F4-31	Corresponding percentage of pulse maximum input	-100.0% to +100.0%	100.0%	0xF41F/0x041F
F4-32	Pulse filter time	0.00s to 10.00s	0.10s	0xF420/0x0420



### 3 Parameters

Param. No.	Param. Name	Setting Range	Default	Communication Address
F4-33	AI curve selection	Ones position: AI curve selection 1: Curve 1 (2 points, see F4-13 to F4-16) 2: Curve 2 (2 points, see F4-18 to F4-21) Tens position: External operating panel potentiometer curve selection, same as above	21	0xF421/0x0421
F4-34	Setting for AI less than minimum input	Ones position: Setting for AI less than minimum input 0: Corresponding percentage of minimum input 1: 0.0% Tens position: Setting for external operating panel potentiometer less than minimum input (same as above)	00	0xF422/0x0422
F4-35	DI1 delay	0.0s to 3600.0s	0.0s	0xF423/0x0423
F4-36	DI2 delay	0.0s to 3600.0s	0.0s	0xF424/0x0424
F4-37	DI3 delay	0.0s to 3600.0s	0.0s	0xF425/0x0425
F4-38	DI active mode selection 1	0: High level active 1: Low level active Ones position: DI1 active mode Tens position: DI2 active mode Hundreds position: DI3 active mode Thousands position: DI4 active mode	0000	0xF426/0x0426
F4-41	DIO terminal type	0: DI/Pulse input 1: DO output	0	0xF429/0x0429

Param. No.	Param. Name	Setting Range	Default	Communication Address
Group F5: Output Terminals				
F5-02	Control board relay function selection (TA/TB/TC)	0: No output 1: AC drive running 2: Fault output (stop upon fault) 3: Frequency-level detection 1 output 4: Frequency reached	19: Undervoltage state output 20: Communication setting 23: Zero-speed running (having output at stop)	2  0xF502/0x0502
F5-04	DIO output function selection (only for MD200XXX-NC)	5: Zero-speed running (no output at stop) 6: Motor overload pre-warning 7: AC drive overload pre-warning 8: Set count value reached 9: Designated count value reached 10: Length reached 11: PLC cycle completed 12: Accumulative running time reached 13: Frequency limited 15: Ready for RUN 17: Frequency upper limit reached 18: Frequency lower limit reached (no output at stop)	24: Accumulative power-on time reached 26: Frequency 1 reached 28: Current 1 reached 30: Timing reached 31: AI input limit exceeded 32: Load lost 33: Reverse running 34: Zero current state 36: Output current exceeding limit 37: Frequency lower limit reached (having output at stop) 38: Alarm output (continue to run) 40: Current running time reached 41: Fault output (no output at undervoltage)	0  0xF504/0x0504

### 3 Parameters

Param. No.	Param. Name	Setting Range	Default	Communication Address
F5-07	AO function selection	0: Running frequency 1: Frequency reference 2: Output current 3: Motor output torque (absolute value) 4: Output power 5: Output voltage 6: Pulse input (100.0% corresponding to 20.00 kHz) 7: AI 8: External operating panel potentiometer 10: Length 11: Count value 12: Communication setting 13: Motor speed 14: Output current (100.0% corresponding to 100.00 A) 15: Bus voltage (100.0% corresponding to 1000.0 V) 16: Motor output torque (actual value)	0	0xF507/0x0507
F5-10	AO zero offset coefficient	-100.0% to +100.0%	0.0%	0xF50A/0x050A
F5-11	AO gain	-10.00 to +10.00	1.00	0xF50B/0x050B
<p>These parameters are used to correct the offset of the analog output zero drift and the output amplitude. They can also be used to define the required AO curve. If "b" represents the zero offset, "k" represents the gain, "Y" represents the actual output, and "X" represents the standard output, the actual output is: <math>Y = kX + b</math>. The AO zero offset coefficient 100% corresponds to 10 V. The standard output refers to the value corresponding to the analog output of 0 to 10 V with no zero offset or gain adjustment. For example, if the analog output is used as the running frequency, and it is expected that the output is 8 V when the frequency is 0 and 3 V at the maximum frequency, the gain shall be set to -0.50, and the zero offset shall be set to 80%.</p>				
F5-18	Relay 1 output delay	0.0s to 3600.0s	0.0s	0xF512/0x0512
F5-20	DIO output delay	0.0s to 3600.0s	0.0s	0xF514/0x0514
F5-22	DO active mode selection	0: Positive logic active 1: Negative logic active Ones position: Reserved Tens position: RELAY1 active mode Hundreds position: Reserved Thousands position: DIO	0000	0xF516/0x0516
<b>Group F6: Start/Stop Control</b>				
F6-00	Start mode	0: Direct start 1: Flying start	0	0xF600/0x0600
F6-01	Flying start mode	3: Quickly switched to the variable frequency from mains frequency 4: Quick flying start	4	0xF601/0x0601
F6-03	Startup frequency	0.00 Hz to 10.00 Hz	0.00 Hz	0xF603/0x0603

Param. No.	Param. Name	Setting Range	Default	Communication Address
F6-04	Startup frequency active time	0.0s to 100.0s	0.0s	0xF604/0x0604
F6-07	Acceleration/ Deceleration mode	0: Linear acceleration/deceleration 2: Dynamic S-curve acceleration/ deceleration	0	0xF607/0x0607
F6-08	Time proportion of S-curve start segment	0.0% to (100.0% – F6-09)	30.0%	0xF608/0x0608
F6-09	Time proportion of S-curve end segment	0.0% to (100.0% – F6-08)	30.0%	0xF609/0x0609
F6-10	Stop mode	0: Decelerate to stop 1: Coast to stop	0	0xF60A/0x060A
F6-11	DC injection braking start frequency	0.00 Hz to 10.00 Hz	0.00 Hz	0xF60B/0x060B
F6-12	Shutdown DC injection braking delay	0.0s to 100.0s	0.0s	0xF60C/0x060C
F6-13	Shutdown DC injection braking current	0% to 100%	50%	0xF60D/0x060D
F6-14	Shutdown DC injection braking active time	0.0s to 100.0s	0.0s	0xF60E/0x060E
F6-21	Demagnetization time	0.00s to 5.00s	0.5s	0xF615/0x0615
F6-22	Minimum output frequency	0.00 Hz to F6-11 (DC injection braking start frequency)	0.00 Hz	0xF616/0x0616
F6-23	Reserved by the manufacturer	1 to 100	10	0xF617/0x0617
<b>Group F7: Operating Panel and Display</b>				
F7-00	LED default display check	0: Disabled 1: Enabled	0	0xF700/0x0700
F7-01	MF.K key function selection	0: MF.K key disabled 1: Switchover between operating panel control and remote command control (terminal or communication) 2: Switchover between forward and reverse running 3: Forward jog (enabled only when the MF.K key is long pressed and disabled after the MF.K key is released) 4: Reverse jog (enabled only when the MF.K key is long pressed and disabled after the MF.K key is released) 5: Parameter display mode switchover	5	0xF701/0x0701

### 3 Parameters

Param. No.	Param. Name	Setting Range	Default	Communication Address
F7-02	STOP/RES key function	0: STOP/RES key enabled only in operating panel control 1: STOP/RES key enabled in any operation mode	1	0xF702/0x0702
F7-03	LED display running parameter 1	0000 to FFFF Bit00: Running frequency (Hz) Bit01: Frequency reference (Hz) Bit02: Bus voltage (V) Bit03: Output voltage (V) Bit04: Output current (A) Bit05: Output power (kW) Bit06: Output torque (%) Bit07: DI state Bit08: DO state Bit09: AI voltage (V) Bit10: Reserved Bit11: External operating panel potentiometer voltage (V) Bit12: Count value Bit13: Length value Bit14: Load speed display Bit15: PID reference	001F	0xF703/0x0703
F7-04	LED display running parameter 2	0000 to FFFF Bit00: PID feedback Bit01: PLC stage Bit02: Pulse input reference (kHz) Bit03: Feedback speed (Hz) Bit04: Remaining running time (min) Bit05: AI1 voltage before correction (V) Bit06: External operating panel potentiometer voltage before correction (V) Bit07: Reserved Bit08: Motor speed (rpm) Bit09: Current power-on time (min) Bit10: Current running time (min) Bit11: Pulse input reference (Hz) Bit12: Communication reference (%) Bit13: Reserved Bit14: Main frequency X display (Hz) Bit15: Auxiliary frequency Y display (Hz)	0000	0xF704/0x0704

Param. No.	Param. Name	Setting Range	Default	Communication Address
F7-05	LED display stop parameters	0000 to 1FFF Bit00: Frequency reference (Hz) Bit01: Bus voltage (V) Bit02: DI state Bit03: DO state Bit04: AI1 voltage (V) Bit05: Reserved Bit06: External operating panel potentiometer voltage (V) Bit07: Count value Bit08: Length value Bit09: PLC stage Bit10: Load speed Bit11: PID reference Bit12: Pulse input reference (kHz)	0033	0xF705/0x0705
F7-06	Load speed display coefficient	0.001 to 65.000	1.000	0xF706/0x0706
F7-07	IGBT heatsink temperature	0°C to 100°C	–	0xF707/0x0707
F7-08	Product SN	200	–	0xF708/0x0708
F7-09	Accumulative running time	0h to 65535h	–	0xF709/0x0709
F7-10	Performance software version	–	–	0xF70A/0x070A
F7-11	Function software version	–	–	0xF70B/0x070B
F7-12	Number of decimal places for monitored speed display	Ones position: Number of decimal places of U0-14 0: 0 decimal places 1: 1 decimal place 2: 2 decimal places Tens position: Number of decimal places of U0-19/U0-29 1: 1 decimal place 2: 2 decimal places	21	0xF70C/0x070C
F7-13	Accumulative power-on time	0h to 65535h	–	0xF70D/0x070D
F7-14	Accumulative power consumption	0 to 65535 kWh	–	0xF70E/0x070E
F7-15	Temporary performance software version	–	–	0xF70F/0x070F
F7-16	Temporary function software version	–	–	0xF710/0x0710
<b>Group F8: Auxiliary Functions</b>				
F8-00	Jog running frequency	0.00 Hz to maximum frequency	2.00 Hz	0xF800/0x0800

### 3 Parameters

Param. No.	Param. Name	Setting Range	Default	Communication Address
F8-01	Jog acceleration time	0.0s to 6500.0s	20.0s	0xF801/0x0801
F8-02	Jog deceleration time	0.0s to 6500.0s	20.0s	0xF802/0x0802
F8-03	Acceleration time 2	0.0s to 6500.0s	20.0s	0xF803/0x0803
F8-04	Deceleration time 2	0.0s to 6500.0s	20.0s	0xF804/0x0804
F8-07	Acceleration time 4	0.0s to 6500.0s	0.0s	0xF807/0x0807
F8-08	Deceleration time 4	0.0s to 6500.0s	0.0s	0xF808/0x0808
F8-12	Forward/Reverse run switchover dead-zone time	0.0s to 3000.0s	0.0s	0xF80C/0x080C
F8-13	Reverse run control	0: Disabled 1: Enabled	0	0xF80D/0x080D
F8-14	Running mode when frequency reference lower than lower limit	0: Run at frequency lower limit 1: Stop 2: Run at zero speed	0	0xF80E/0x080E
F8-16	Accumulative power-on time threshold	0h to 65000h	0h	0xF810/0x0810
F8-17	Accumulative running time threshold	0h to 65000h	0h	0xF811/0x0811
F8-18	Startup protection	0: Disabled 1: Enabled	0	0xF812/0x0812
F8-19	Frequency detection value (FDT)	0.00 Hz to maximum frequency	50.00 Hz	0xF813/0x0813
F8-20	Frequency detection hysteresis (FDT)	0.0% to 100.0% (FDT1 level)	5.0%	0xF814/0x0814
F8-21	Measured width when frequency reached	0.0% to 100.0% (maximum frequency)	0.0%	0xF815/0x0815
F8-25	Switchover frequency of acceleration time 1 and acceleration time 2	0.00 Hz to maximum frequency	0.00 Hz	0xF819/0x0819
F8-26	Switchover frequency of deceleration time 1 and deceleration time 2	0.00 Hz to maximum frequency	0.00 Hz	0xF81A/0x081A
F8-27	Terminal jog preferred	0: Disabled 1: Enabled	0	0xF81B/0x081B
F8-30	Detection of frequency	0.00 Hz to maximum frequency	50.00 Hz	0xF81E/0x081E

Param. No.	Param. Name	Setting Range	Default	Communication Address
F8-31	Detection width of frequency	0.0% to 100.0% (maximum frequency)	0.0%	0xF81F/0x081F
F8-34	Zero current detection level	0.0% to 300.0% The value 100.0% corresponds to the rated motor current.	5.0%	0xF822/0x0822
F8-35	Zero current detection delay	0.01s to 600.00s	0.10s	0xF823/0x0823
F8-36	Output overcurrent threshold	0.0% (no detection) 0.1% to 300.0% (rated motor current)	200.0%	0xF824/0x0824
F8-37	Output overcurrent detection delay	0.00s to 600.00s	0.00s	0xF825/0x0825
F8-38	Detection level of current 1	0.0% to 300.0% (rated motor current)	100.0%	0xF826/0x0826
F8-39	Measured width 1 when current reached	0.0% to 300.0% (rated motor current)	0.0%	0xF827/0x0827
F8-42	Timing function	0: Disabled 1: Enabled	0	0xF82A/0x082A
F8-43	Timing duration source	0: Set by F8-44 (Timing duration) 1: AI 2: External operating panel potentiometer 100% of analog input corresponds to the value of F8-44 (Timing duration).	0	0xF82B/0x082B
F8-44	Timing duration	0.0 to 6500.0 min	0.0 min	0xF82C/0x082C
F8-45	AI input voltage lower limit	0.00 V to F8-46 (AI input voltage upper limit)	3.10 V	0xF82D/0x082D
F8-46	AI input voltage upper limit	F8-45 (AI input voltage lower limit) to 11.00 V	6.80 V	0xF82E/0x082E
F8-48	Cooling fan working mode	0: Working during AC drive running 1: Working continuously 2: Working when temperature reached	0	0xF830/0x0830
F8-49	Wakeup frequency	F8-51 (Hibernating frequency) to F0-10 (Maximum frequency)	0.00 Hz	0xF831/0x0831
F8-50	Wakeup delay	0.0s to 6500.0s	0.0s	0xF832/0x0832
F8-51	Hibernating frequency	0.00 Hz to F8-49 (Wakeup frequency)	0.00 Hz	0xF833/0x0833
F8-52	Hibernating delay	0.0s to 6500.0s	0.0s	0xF834/0x0834
F8-53	Current running time reached	0.0 to 6500.0 min	0.0 min	0xF835/0x0835
F8-54	Output power correction coefficient	0.0% to 200.0%	100.0%	0xF836/0x0836
F8-55	Emergency deceleration time	0.0s to 6500.0s	10.0s	0xF837/0x0837
F8-57	Speed synchronous control selection	0: Disabled 1: Enabled	0	0xF839/0x0839



### 3 Parameters

Param. No.	Param. Name	Setting Range	Default	Communication Address
<p>This parameter is used to set the speed synchronous control function.</p> <p>The speed synchronous control function is to enable direct data communication between two or more MD200 AC drives using CANlink for synchronizing the target frequency of one or more slaves with the target frequency of the master.</p> <p>When this function is enabled, the CANlink communication addresses of the master and slaves match automatically. No further configuration is required.</p> <p>The communication speed of this function is set by Fd-00 (Baud rate).</p>				

F8-58	Master/Slave selection in synchronous control	0: Master 1: Slave	0	0xF83A/0x083A
-------	---	-----------------------	---	---------------

This parameter is used to set the AC drive as a master or slave. When this parameter is set to 1, manually set F0-03 (Main frequency source X selection) to 9 (Communication setting).

#### Group F9: Fault and Protection

F9-00	Motor overload protection	0: Disabled 1: Enabled	1	0xF900/0x0900
F9-01	Motor overload protection gain	0.20 to 10.00	0.20	0xF901/0x0901

F9-00 = 0: The motor overload protection function is disabled. The motor may be damaged due to overheating. Therefore, it is suggested that a thermal relay be installed between the AC drive and the motor.

F9-00 = 1: The AC drive determines whether the motor is overloaded according to the inverse time-lag curve of motor overload protection.

The inverse time-lag curve of motor overload protection is:  $195\% \times F9-01 \times \text{Rated motor current}$  (if the load remains at this value for 1 minute, the AC drive reports the motor overload fault); or  $150\% \times F9-01 \times \text{Rated motor current}$  (if the load remains at this value for 5 minutes, the AC drive reports the motor overload fault)

Set F9-01 properly based on the actual overload capacity. If the value of F9-01 is set too large, the motor may be damaged because the motor overheats but the AC drive does not report the alarm.

F9-02	Motor overload pre-warning coefficient	50% to 100%	80%	0xF902/0x0902
-------	--	-------------	-----	---------------

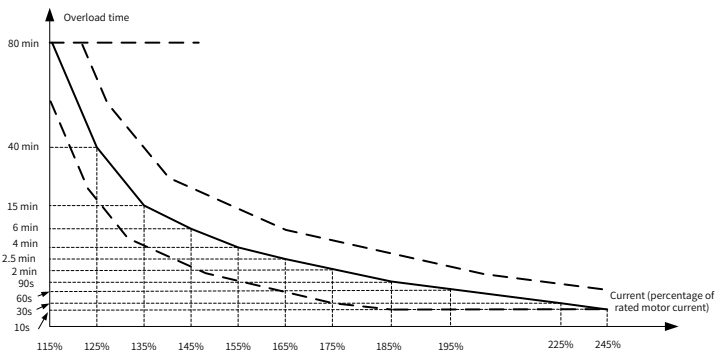

#### Inverse time-lag curve of motor overload protection

When the motor running current reaches 175% of the rated motor current and the motor runs at this level for 2 minutes, Err11 (motor overload) is detected. When the motor running current reaches

Param. No.	Param. Name	Setting Range	Default	Communication Address
<p>115% of the rated motor current and the motor runs at this level for 80 minutes, Err11 (motor overload) is detected.</p> <p>Example: The rated motor current is 100 A.</p> <p>If F9-01 (Motor overload protection gain) is set to 1.00, when the motor running current reaches 125 A (125% of 100 A) and the motor runs at 125 A for 40 minutes, the AC drive reports Err11 (motor overload).</p> <p>If F9-01 (Motor overload protection gain) is set to 1.20, when the motor running current reaches 125 A (125% of 100 A) and the motor runs at 125 A for 48 minutes (40 x 1.2), the AC drive reports Err11 (motor overload).</p> <p>The maximum overload time is 80 minutes and the minimum overload time is 10 seconds.</p> <p>For example, if the AC drive is required to report the overload fault when the motor runs at 150% of the rated current for 2 minutes:</p> <p>According to the motor overload curve, 150% (I) is in the range of 145% (I1) and 155% (I2). 145% corresponds to the overload protection time 6 minutes (T1) and 155% corresponds to overload protection time 4 minutes (T2). It can be concluded that in default settings, the overload protection time for 150% rated current of the motor is 5 minutes according to the formula below.</p> $T = T1 + (T2 - T1) \times (I - I1) / (I2 - I1) = 4 + (6 - 4) \times (150\% - 145\%) / (155\% - 145\%) = 5 \text{ minutes}$ <p>Then, calculate the motor overload protection gain from the following formula:</p> $F9-01 = 2 / 5 = 0.4$ <p>Note: Set F9-01 (Motor overload protection gain) properly based on the actual overload capacity. If the value of F9-01 (Motor overload protection gain) is set too large, the motor may be damaged because the motor overheats but the AC drive does not report the alarm timely.</p> <p>When the motor overload detection level reaches the value of F9-02 (Motor overload pre-warning coefficient), the DO or fault relay outputs the motor overload pre-warning signal. The value of F9-02 (Motor overload pre-warning coefficient) is the percentage of the time duration during which the motor runs continuously without reporting the overload fault.</p> <p>On the condition that F9-01 (Motor overload protection gain) is set to 1.00 and F9-02 (Motor overload pre-warning coefficient) is set to 80%, when the motor running current reaches 145% of the rated motor current and the motor runs at this level for 4.8 minutes (80% x 6), the DO terminal or fault relay outputs the motor overload pre-warning signal.</p>				
F9-07	Protection against short circuit to ground upon power-on	0: Disabled 1: Enabled	1	0xF907/0x0907
F9-08	Braking unit applied voltage	310.0 V to 800.0 V	Single-phase: 378.0 V Three-phase: 700.0 V	0xF908/0x0908
F9-09	Fault auto reset times	0 to 20	0	0xF909/0x0909
F9-10	DO action during auto fault reset	0: Not act 1: Act	0	0xF90A/0x090A
F9-11	Auto fault reset interval	0.1s to 100.0s	1.0s	0xF90B/0x090B
F9-12	Input phase loss protection	0: Disabled 1: Enabled	1	0xF90C/0x090C

### 3 Parameters

Param. No.	Param. Name	Setting Range	Default	Communication Address		
F9-13	Output phase loss protection	0: Disabled 1: Enabled	1	0xF90D/0x090D		
F9-14	1st fault type	<table border="0"> <tr> <td style="vertical-align: top;">                     0: No fault 1: Reserved 2: Overcurrent during acceleration 3: Overcurrent during deceleration 4: Overcurrent during constant speed 5: Overvoltage during acceleration 6: Overvoltage during deceleration 7: Overvoltage during constant speed 8: Pre-charge resistor overload 9: Undervoltage 10: AC drive overload 11: Motor overload 12: Input phase loss 13: Output phase loss 14: IGBT overheat 15: External fault 16: Communication abnormal 17: Reserved 18: Current detection fault                 </td> <td style="vertical-align: top;">                     19: Motor auto-tuning abnormal 20: Reserved 21: Parameter read/write abnormal 22: Reserved 23: Motor short circuit to ground 24: Reserved 25: Reserved 26: Running time reached 29: Accumulative power-on time reached 30: Load lost 31: PID feedback lost during running 40: Fast current limit timeout 41: Reserved 42: Excessive speed deviation 43: Reserved 45: Reserved 51: Reserved 55: Slave fault in speed synchronization                 </td> </tr> </table>	0: No fault 1: Reserved 2: Overcurrent during acceleration 3: Overcurrent during deceleration 4: Overcurrent during constant speed 5: Overvoltage during acceleration 6: Overvoltage during deceleration 7: Overvoltage during constant speed 8: Pre-charge resistor overload 9: Undervoltage 10: AC drive overload 11: Motor overload 12: Input phase loss 13: Output phase loss 14: IGBT overheat 15: External fault 16: Communication abnormal 17: Reserved 18: Current detection fault	19: Motor auto-tuning abnormal 20: Reserved 21: Parameter read/write abnormal 22: Reserved 23: Motor short circuit to ground 24: Reserved 25: Reserved 26: Running time reached 29: Accumulative power-on time reached 30: Load lost 31: PID feedback lost during running 40: Fast current limit timeout 41: Reserved 42: Excessive speed deviation 43: Reserved 45: Reserved 51: Reserved 55: Slave fault in speed synchronization	-	0xF90E/0x090E
0: No fault 1: Reserved 2: Overcurrent during acceleration 3: Overcurrent during deceleration 4: Overcurrent during constant speed 5: Overvoltage during acceleration 6: Overvoltage during deceleration 7: Overvoltage during constant speed 8: Pre-charge resistor overload 9: Undervoltage 10: AC drive overload 11: Motor overload 12: Input phase loss 13: Output phase loss 14: IGBT overheat 15: External fault 16: Communication abnormal 17: Reserved 18: Current detection fault	19: Motor auto-tuning abnormal 20: Reserved 21: Parameter read/write abnormal 22: Reserved 23: Motor short circuit to ground 24: Reserved 25: Reserved 26: Running time reached 29: Accumulative power-on time reached 30: Load lost 31: PID feedback lost during running 40: Fast current limit timeout 41: Reserved 42: Excessive speed deviation 43: Reserved 45: Reserved 51: Reserved 55: Slave fault in speed synchronization					
F9-15	2nd fault type	Same as the values of F9-14 (1st fault type)	-	0xF90F/0x090F		
F9-16	3rd (latest) fault type	Same as the values of F9-14 (1st fault type)	-	0xF910/0x0910		
F9-17	Frequency upon 3rd fault	-	-	0xF911/0x0911		
F9-18	Current upon 3rd (latest) fault	-	-	0xF912/0x0912		
F9-19	Bus voltage upon 3rd (latest) fault	-	-	0xF913/0x0913		
F9-20	DI state upon 3rd (latest) fault	-	-	0xF914/0x0914		
F9-21	DO state upon 3rd (latest) fault	-	-	0xF915/0x0915		

Param. No.	Param. Name	Setting Range	Default	Communication Address
F9-22	AC drive state upon 3rd (latest) fault	-	-	0xF916/0x0916
F9-23	Power-on time upon 3rd (latest) fault	-	-	0xF917/0x0917
F9-24	Running time upon 3rd (latest) fault	-	-	0xF918/0x0918
F9-27	Frequency upon 2nd fault	-	-	0xF91B/0x081B
F9-28	Current upon 2nd fault	-	-	0xF91C/0x091C
F9-29	Bus voltage upon 2nd fault	-	-	0xF91D/0x091D
F9-30	DI state upon 2nd fault	-	-	0xF91E/0x091E
F9-31	DO state upon 2nd fault	-	-	0xF91F/0x091F
F9-32	AC drive state upon 2nd fault	-	-	0xF920/0x0920
F9-33	Power-on time upon 2nd fault	-	-	0xF921/0x0921
F9-34	Running time upon 2nd fault	-	-	0xF922/0x0922
F9-37	Frequency upon 1st fault	-	-	0xF925/0x0925
F9-38	Current upon 1st fault	-	-	0xF926/0x0926
F9-39	Bus voltage upon 1st fault	-	-	0xF927/0x0927
F9-40	DI state upon 1st fault	-	-	0xF928/0x0928
F9-41	DO state upon 1st fault	-	-	0xF929/0x0929
F9-42	AC drive state upon 1st fault	-	-	0xF92A/0x092A
F9-43	Power-on time upon 1st fault	-	-	0xF92B/0x092B
F9-44	Running time upon 1st fault	-	-	0xF92C/0x092C

3 Parameters

Param. No.	Param. Name	Setting Range	Default	Communication Address		
F9-47	Fault protection action selection	<p>Ones position: Motor overload (11)                      0: Coast to stop                      1: Stop according to the stop mode                      2: Continue to run                      Tens position: Input phase loss (12)                      Hundreds position: Output phase loss (13)                      Thousands position: External fault (15)                      Ten thousands position:                      Communication abnormal (16)</p>	0	0xF92F/0x092F		
F9-48	Fault protection action 2	<p>Ones position: Reserved                      Tens position: Parameter read/write abnormal (21)                      0: Coast to stop                      1: Stop according to the stop mode                      Hundreds position: AC drive overload                      0: Overload protection disabled                      1: Overload protection enabled                      Thousands position: Reserved                      Ten thousands position: Running time reached (26)</p>	0	0xF930/0x0930		
F9-49	Fault protection action 3	<table border="0"> <tr> <td style="vertical-align: top;"> <p>Ones position: User-defined fault 1 (27)                              0: Coast to stop                              1: Stop according to the stop mode                              2: Continue to run                              Tens position: User-defined fault 2 (28)                              0: Coast to stop                              1: Stop according to the stop mode                              2: Continue to run                              Hundreds position: Power-on time reached (29)                              0: Coast to stop                              1: Stop according to the stop mode                              2: Continue to run</p> </td> <td style="vertical-align: top;"> <p>Thousands position: Load lost (30)                              0: Coast to stop                              1: Decelerate to stop                              2: Continue to run at 7% of rated motor frequency and resume to the set frequency if the load recovers                                Ten thousands position: PID feedback lost during running (31)                              0: Coast to stop                              1: Stop according to the stop mode                              2: Continue to run</p> </td> </tr> </table>	<p>Ones position: User-defined fault 1 (27)                              0: Coast to stop                              1: Stop according to the stop mode                              2: Continue to run                              Tens position: User-defined fault 2 (28)                              0: Coast to stop                              1: Stop according to the stop mode                              2: Continue to run                              Hundreds position: Power-on time reached (29)                              0: Coast to stop                              1: Stop according to the stop mode                              2: Continue to run</p>	<p>Thousands position: Load lost (30)                              0: Coast to stop                              1: Decelerate to stop                              2: Continue to run at 7% of rated motor frequency and resume to the set frequency if the load recovers                                Ten thousands position: PID feedback lost during running (31)                              0: Coast to stop                              1: Stop according to the stop mode                              2: Continue to run</p>	0	0xF931/0x0931
<p>Ones position: User-defined fault 1 (27)                              0: Coast to stop                              1: Stop according to the stop mode                              2: Continue to run                              Tens position: User-defined fault 2 (28)                              0: Coast to stop                              1: Stop according to the stop mode                              2: Continue to run                              Hundreds position: Power-on time reached (29)                              0: Coast to stop                              1: Stop according to the stop mode                              2: Continue to run</p>	<p>Thousands position: Load lost (30)                              0: Coast to stop                              1: Decelerate to stop                              2: Continue to run at 7% of rated motor frequency and resume to the set frequency if the load recovers                                Ten thousands position: PID feedback lost during running (31)                              0: Coast to stop                              1: Stop according to the stop mode                              2: Continue to run</p>					
F9-54	Frequency selection for continuing to run upon fault	<p>0: Current running frequency                      1: Frequency reference                      2: Frequency upper limit                      3: Frequency lower limit                      4: Backup frequency upon abnormality</p>	0	0xF936/0x0936		

Param. No.	Param. Name	Setting Range	Default	Communication Address
F9-55	Backup frequency upon abnormality	0.0% to 100.0% (maximum frequency, F0-10)	100.00%	0xF937/0x0937
F9-59	Power dip ride-through function selection	0: Disabled 1: Decelerate 2: Decelerate to stop	0	0xF93B/0x093B
F9-60	Threshold of power dip ride through function disabled	80% to 100% (standard bus voltage)	85%	0xF93C/0x093C
F9-61	Judging time of bus voltage recovering from power dip	0.0s to 100.0s	0.50s	0xF93D/0x093D
F9-62	Threshold of power dip ride-through function enabled	60.0% to F9-60 (Standard bus voltage)	80.0%	0xF93E/0x093E
F9-63	Protection upon load loss	0: Disabled 1: Enabled	0	0xF93F/0x093F
F9-64	Load loss detection level	0.0% to 100.0%	10.0%	0xF940/0x0940
F9-65	Load loss detection time	0.0s to 60.0s	1.0s	0xF941/0x0941
F9-71	Power dip ride-through gain Kp	0 to 100	40	0xF947/0x0947
F9-72	Power dip ride-through integral coefficient Ki	0 to 100	30	0xF948/0x0948
F9-73	Deceleration time of power dip ride-through	0.0s to 300.0s	20.0s	0xF949/0x0949
F9-74	Restart mode after fault reset	0: Normal 1: Flying start	0	0xF94A/0x094A

When the bus voltage drops below the value of F9-62 (Threshold of power dip ride-through function enabled), the power dip ride through process starts. The AC drive output frequency decreases automatically to keep the motor in the regenerative state and keep the bus voltage around the value of F9-62 (Threshold of power dip ride-through function enabled), so that the system can decelerate to 0 Hz normally. The following figure shows the power dip ride-through process.

Param. No.	Param. Name	Setting Range	Default	Communication Address
------------	-------------	---------------	---------	-----------------------

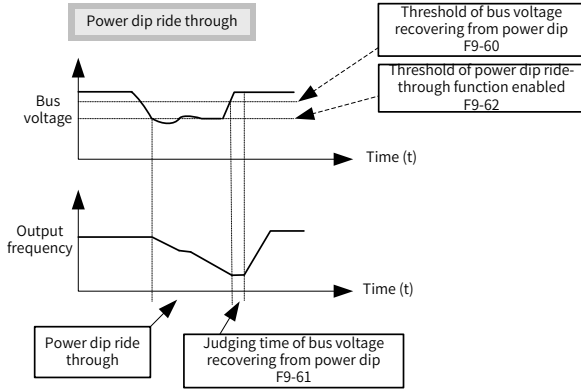

Note: (1) In the bus voltage constant control mode, when the power supply recovers, the AC drive output frequency increases gradually to the target frequency. In the deceleration to stop mode, when the power supply recovers, the AC drive gradually decelerates to 0 Hz and stops until receiving a start command again.

(2) The power dip ride through function is to ensure that the motor can decelerate to stop normally when the power supply is abnormal rather than coasting to stop due to undervoltage and then the motor can start immediately after the power supply recovers. In the large-inertia system, it takes a long time for the motor to coast to stop. After the power supply recovers, if the motor is started when it is still running at speed, the AC drive is prone to report an overload or overcurrent fault.

**Group FA: PID Function**

PID control is a general process control method. By performing proportional, integral, and differential operations on the difference between the feedback signal and the target signal, it adjusts the AC drive output frequency and constitutes a feedback system to stabilize the controlled counter around the target value.

It is applied to process control such as flow control, pressure control, and temperature control. The following figure shows the PID control principle.

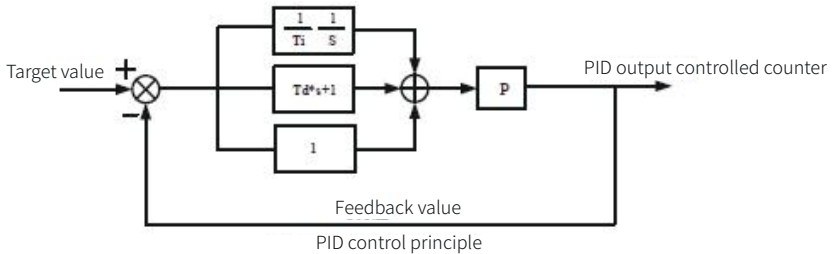

PID control principle

Param. No.	Param. Name	Setting Range	Default	Communication Address
FA-00	PID reference setting channel	0: Set by FA-01 (PID digital reference) 1: AI 2: External operating panel potentiometer 4: Pulse reference (DI4) 5: Communication setting 6: Multi-reference	0	0xFA00/0x0A00
FA-01	PID digital reference	0.0% to 100.0%	50.0%	0xFA01/0x0A01
This parameter is used to select the target process PID setting channel. The PID setting is a relative value ranging from 0.0% to 100.0%. The PID feedback is also a relative value. The purpose of PID control is to make the PID setting and PID feedback equal.				
FA-02	PID feedback setting channel	0: AI 1: External operating panel potentiometer 3: AI – External operating panel potentiometer 4: Pulse reference (DI4) 5: Communication setting 6: AI + External operating panel potentiometer 7: Max. (   AI   ,   External operating panel potentiometer   ) 8: Min. (   AI   ,   External operating panel potentiometer   )	0	0xFA02/0x0A02
This parameter is used to select the feedback signal channel of process PID. The PID feedback is a relative value ranging from 0.0% to 100.0%.				
FA-03	PID action direction	0: Forward 1: Reverse	0	0xFA03/0x0A03
Forward operation: When the PID feedback is lower than the PID reference, the output frequency of the AC drive increases. For example, the winding tension control requires forward PID operation. Reverse operation: When the PID feedback is lower than the PID reference, the output frequency of the AC drive decreases. For example, the unwinding tension control requires reverse PID operation. Note that this function is influenced by the DI function 35 (Reverse PID action direction).				
FA-04	PID reference and feedback range	0 to 65535	1000	0xFA04/0x0A04
This parameter is a non-dimensional unit. It is used for PID setting display (U0-15) and PID feedback display (U0-16). The relative value 100.0% of PID setting feedback corresponds to the value of FA-04. If FA-04 is set to 2000 and PID setting is 100.0%, the PID setting display (U0-15) is 2000.				
FA-05	Proportional gain Kp1	0.0 to 1000.0	20	0xFA05/0x0A05
FA-06	Integral time Ti1	0.01s to 10.00s	2.00s	0xFA06/0x0A06
FA-07	Differential time Td1	0.000s to 10.000s	0.000s	0xFA07/0x0A07



### 3 Parameters

Param. No.	Param. Name	Setting Range	Default	Communication Address
<p>FA-05 (Proportional gain Kp1): It decides the regulating intensity of the PID function. The larger the Kp1 is, the greater the regulating intensity will be obtained. When this parameter is set to 1000.0, the deviation between PID feedback and PID setting is 1000.0%. In this case, the adjustment amplitude of the PID regulator on the output frequency reference is the maximum frequency.</p> <p>FA-06 (Integral time Ti1) It decides the integral regulating intensity of the PID function. The shorter the integral time is, the greater regulating intensity will be obtained. When the deviation between PID feedback and PID reference is 100.0%, the integral regulator performs continuous adjustment for the time set by FA-06. Then, the adjustment amplitude reaches the maximum frequency.</p> <p>FA-07 (Differential time Td1) It decides the regulating intensity of the PID regulator on the deviation change. The longer the differential time is, the larger the regulating intensity will be obtained. Differential time is the time within which the feedback value change reaches 100.0%, and then the adjustment amplitude reaches the maximum frequency.</p>				
FA-08	PID output limit in reverse direction	0.00 Hz to the maximum frequency	0.00 Hz	0xFA08/0x0A08
FA-09	PID error limit	0.0% to 100.0%	0.0%	0xFA09/0x0A09
<p>If the deviation between PID feedback and PID setting is lower than the value of FA-09, PID control stops. The small deviation between PID feedback and PID setting will stabilize the output frequency, which is effective for some closed-loop control applications.</p>				
FA-10	PID differential limit	0.0% to 100.0%	0.1%	0xFA0A/0x0A0A
<p>It is used to set the PID differential output range. In PID control, the differential operation may easily cause system oscillation. Therefore, the PID differential regulation is restricted to a small range.</p>				
FA-11	PID reference change time	0.00s to 650.00s	0.00s	0xFA0B/0x0A0B
<p>The PID setting change time indicates the time required for the PID setting changing from 0.0% to 100.0%. The PID setting changes linearly according to the change time, reducing the impact caused by sudden setting change on the system.</p>				
FA-12	PID feedback filter time	0.00s to 60.00s	0.00s	0xFA0C/0x0A0C
FA-13	PID output filter time	0.00s to 60.00s	0.00s	0xFA0D/0x0A0D
<p>FA-12 is used to filter the PID feedback, helping to reduce interference on the feedback. However, this slows the response of the process closed-loop system. FA-13 is used to filter the PID output frequency, helping to weaken sudden change of the AC drive output frequency. However, this slows the response of the process closed-loop system.</p>				
FA-15	Proportional gain Kp2	0.0 to 1000.0	20	0xFA0F/0x0A0F
FA-16	Integral time Ti2	0.01s to 10.00s	2.00s	0xFA10/0x0A10
FA-17	Differential time Td2	0.000s to 10.000s	0.000s	0xFA11/0x0A11

Param. No.	Param. Name	Setting Range	Default	Communication Address
FA-18	PID parameter switchover condition	0: No switchover 1: Switchover by DI 2: Automatic switchover based on deviation 3: Automatic switchover based on running frequency	0	0xFA12/0x0A12
FA-19	PID parameter switchover deviation 1	0.0% to FA-20 (PID parameter switchover deviation 2)	20.0%	0xFA13/0x0A13
FA-20	PID parameter switchover deviation 2	FA-19 (PID parameter switchover deviation 1) to 100.0%	80.0%	0xFA14/0x0A14

In some applications, PID parameter switchover is required when one group of PID parameters cannot satisfy the requirements of the whole running process.

These parameters are used for switchover between two groups of PID parameters. Regulator parameters FA-15 (Proportional gain Kp2) to FA-17 (Differential time Td2) are set in the same way as FA-05 (Proportional gain Kp1) to FA-07(Differential time Td1).

The switchover can be implemented either through a DI terminal or automatically implemented based on the deviation.

To enable switchover through a DI terminal, allocate the DI with function 43 (PID parameter switchover). If the DI is invalid, group 1 (FA-05 to FA-07) is selected. If the DI is valid, group 2 (FA-15 to FA-17) is selected.

If automatic switchover is enabled, when the absolute value of the deviation between the PID feedback and PID setting is lower than the value of FA-19 (PID parameter switchover deviation 1), group 1 is selected. When the absolute value of the deviation between the PID feedback and PID setting is higher than the value of FA-20 (PID parameter switchover deviation 2), group 2 is selected. When the deviation is between FA-19 (PID parameter switchover deviation 1) and FA-20 (PID parameter switchover deviation 2), the PID parameters are the linear interpolated value of the two groups of parameter values, as shown in the following figure.

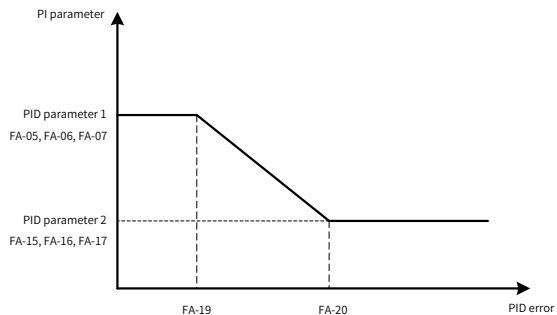

FA-21	PID initial value	0.0% to 100.0%	0.0%	0xFA15/0x0A15
FA-22	PID initial value active time	0.00s to 650.00s	0.00s	0xFA16/0x0A16

### 3 Parameters

Param. No.	Param. Name	Setting Range	Default	Communication Address
------------	-------------	---------------	---------	-----------------------

When the AC drive starts up, the PID starts closed-loop algorithm only after the PID output is fixed to the PID initial value (FA-21) and lasts the time set by FA-22.

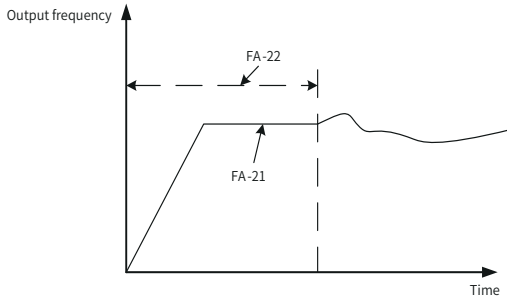

PID initial value function

This function limits the difference between two PID outputs (at an interval of 2 ms) to avoid quick PID output change and stabilize the AC drive running.

FA-23	Maximum positive error of two outputs	0.00% to 100.00%	1.00%	0xFA17/0x0A17
FA-24	Maximum negative error of two outputs	0.00% to 100.00%	1.00%	0xFA18/0x0A18

FA-23 and FA-24 correspond to the maximum absolute value of the output deviation in the forward direction and in reverse direction, respectively.

FA-25	PID integral property	<p>Ones position: Integral separation                      0: Disabled                      1: Enabled</p> <p>Tens position: Whether to stop integral operation when the output reaches the limit                      0: Continue integral operation                      1: Stop integral operation</p>	0	0xFA19/0x0A19
-------	-----------------------	---	---	---------------

#### Integral separation:

If the integral separation is valid (ones position set to 1), the PID integral operation stops when the DI allocated with function 38 (PID integral pause) is valid. In this case, only proportional and differential operations take effect.

If the integral separation is invalid (ones position set to 0), the integral separation remains invalid no matter whether the DI is valid.

Whether to stop integral operation when the output reaches the limit:

When the PID calculation output reaches the maximum or minimum value, you can select whether to stop the integral operation. If you select to stop the integral operation (tens position set to 1), the PID integral operation stops, which may help to reduce the PID overshoot.

FA-26	Detection level of PID feedback loss	0.0%: No detection 0.1% to 100.0%	0.0%	0xFA1A/0x0A1A
FA-27	Detection time of PID feedback loss	0.0s to 20.0s	0.0s	0xFA1B/0x0A1B

Param. No.	Param. Name	Setting Range	Default	Communication Address
These parameters are used to check whether the PID feedback is lost. If the PID feedback is lower than the value of FA-26 and the lasting time exceeds the value of FA-27, the AC drive reports Err31 and acts according to the selected fault protection action.				
FA-28	Selection of PID operation at stop	0: Disabled 1: Enabled	0	0xFA1C/0x0A1C
It is used to determine whether to continue PID operation when the AC drive stops. Generally, the PID operation is disabled when the AC drive stops.				
<b>Group Fb: Wobble Function, Fixed Length, and Count</b>				
Fb-00	Wobble setting mode	0: Relative to the central frequency 1: Relative to the maximum frequency	0	0xFB00/0x0B00
Fb-01	Wobble amplitude	0.0% to 100.0%	0.0%	0xFB01/0x0B01
Fb-02	Wobble step	0.0% to 50.0%	0.0%	0xFB02/0x0B02
Fb-03	Wobble cycle	0.1s to 3000.0s	10.0s	0xFB03/0x0B03
Fb-04	Triangular wave rising time coefficient	0.1% to 100.0%	50.0%	0xFB04/0x0B04
Fb-05	Set length	0 to 65535 m	1000 m	0xFB05/0x0B05
Fb-06	Actual length	0 to 65535 m	0 m	0xFB06/0x0B06
Fb-07	Number of pulses per meter	0.1 to 6553.5	100.0	0xFB07/0x0B07
Fb-08	Set count value	1 to 65535	1000	0xFB08/0x0B08
Fb-09	Designated count value	1 to 65535	1000	0xFB09/0x0B09
<b>Group FC: Multi-Reference and Simple PLC Function</b>				
FC-00	Reference 0	-100.0% to +100.0%	0.00%	0xFC00/0x0C00
FC-01	Reference 1	-100.0% to +100.0%	0.00%	0xFC01/0x0C01
FC-02	Reference 2	-100.0% to +100.0%	0.00%	0xFC02/0x0C02
FC-03	Reference 3	-100.0% to +100.0%	0.00%	0xFC03/0x0C03
FC-04	Reference 4	-100.0% to +100.0%	0.00%	0xFC04/0x0C04
FC-05	Reference 5	-100.0% to +100.0%	0.00%	0xFC05/0x0C05
FC-06	Reference 6	-100.0% to +100.0%	0.00%	0xFC06/0x0C06
FC-07	Reference 7	-100.0% to +100.0%	0.00%	0xFC07/0x0C07
FC-16	Simple PLC running mode	0: Stop after running for one cycle 1: Keep final values after running for one cycle 2: Repeat after running for one cycle	0	0xFC10/0x0C10
FC-17	Simple PLC retentive selection	Ones position: Retentive upon power failure selection 0: Non-retentive upon power failure 1: Retentive upon power failure Tens position: Retentive upon stop 0: Non-retentive upon stop 1: Retentive upon stop	0	0xFC11/0x0C11
FC-18	Running time of simple PLC reference 0	0.0s (h) to 6500.0s (h)	0.0s(h)	0xFC12/0x0C12

### 3 Parameters

Param. No.	Param. Name	Setting Range	Default	Communication Address
FC-19	Acceleration/ Deceleration time of simple PLC reference 0	0 to 1	0	0xFC13/0x0C13
FC-20	Running time of simple PLC reference 1	0.0s (h) to 6500.0s (h)	0.0s(h)	0xFC14/0x0C14
FC-21	Acceleration/ Deceleration time of simple PLC reference 1	0 to 1	0	0xFC15/0x0C15
FC-22	Running time of simple PLC reference 2	0.0s (h) to 6500.0s (h)	0.0s(h)	0xFC16/0x0C16
FC-23	Acceleration/ Deceleration time of simple PLC reference 2	0 to 1	0	0xFC17/0x0C17
FC-24	Running time of simple PLC reference 3	0.0s (h) to 6500.0s (h)	0.0s(h)	0xFC18/0x0C18
FC-25	Acceleration/ Deceleration time of simple PLC reference 3	0 to 1	0	0xFC19/0x0C19
FC-26	Running time of simple PLC reference 4	0.0s (h) to 6500.0s (h)	0.0s(h)	0xFC1A/0x0C1A
FC-27	Acceleration/ Deceleration time of simple PLC reference 4	0 to 1	0	0xFC1B/0x0C1B
FC-28	Running time of simple PLC reference 5	0.0s (h) to 6500.0s (h)	0.0s(h)	0xFC1C/0x0C1C
FC-29	Acceleration/ Deceleration time of simple PLC reference 5	0 to 1	0	0xFC1D/0x0C1D
FC-30	Running time of simple PLC reference 6	0.0s (h) to 6500.0s (h)	0.0s(h)	0xFC1E/0x0C1E
FC-31	Acceleration/ Deceleration time of simple PLC reference 6	0 to 1	0	0xFC1F/0x0C1F

Param. No.	Param. Name	Setting Range		Default	Communication Address
FC-32	Running time of simple PLC reference 7	0.0s (h) to 6500.0s (h)		0.0s(h)	0xFC20/0x0C20
FC-33	Acceleration/Deceleration time of simple PLC reference 7	0 to 1		0	0xFC21/0x0C21
FC-50	Time unit of simple PLC running	0: s (second) 1: h (hour)		0	0xFC32/0x0C32
FC-51	Reference 0 source	0: Set by FC-00 (Reference 0) 1: AI 2: External operating panel potentiometer 4: Pulse reference 5: PID 6: Set by F0-08 (Preset frequency), modified using terminal UP/DOWN		0	0xFC33/0x0C33
<b>Group Fd: Communication Parameters</b>					
Fd-00	Baud rate	Ones position: Modbus 0: 300 bps 1: 600 bps 2: 1200 bps 3: 2400 bps 4: 4800 bps 5: 9600 bps 6: 19200 bps 7: 38400 bps 8: 57600 bps 9: 115200 bps	Tens position: Reserved Hundreds position: Reserved Ten thousands position: CANlink baud rate 0: 20 Kbps 1: 50 Kbps 2: 75 Kbps 3: 125 Kbps 4: 250 Kbps 5: 500 Kbps	5005	0xFD00/0x0D00
Fd-01	Modbus data format	0: No check (8-N-2) 1: Even parity check (8-E-1) 2: Odd parity check (8-O-1) 3: No check (8- N-1) (valid for Modbus)		0	0xFD01/0x0D01
Fd-02	Local address	0: Broadcast address 1 to 247 (valid for Modbus and CANlink)		1	0xFD02/0x0D02
Fd-03	Modbus response delay	0 to 20 ms (valid for Modbus)		2	0xFD03/0x0D03
Fd-04	Serial port communication timeout	0.0 (invalid); 0.1s to 60.0s (valid for Modbus)		0	0xFD04/0x0D04
Fd-05	Data transmission format	0: Non-standard Modbus protocol 1: Standard Modbus protocol		1	0xFD05/0x0D05

### 3 Parameters

Param. No.	Param. Name	Setting Range	Default	Communication Address
The following table describes the difference between the non-standard and standard Modbus protocols.				
		Non-standard Modbus Protocol (Fd-05 = 0)	Standard Modbus Protocol (Fd-05 = 1)	
	ADR	01H	ADR	01H
	CMD	03H	CMD	03H
	Byte number high order	00H	Byte number	04H
	Byte number low order	04H	-	-
	Data F002H high order	00H	Data F002H high order	00H
	Data F002H low order	00H	Data F002H low order	00H
	Data F003H high order	00H	Data F003H high order	00H
	Data F003H high order	01H	Data F003H low order	01H
	CRC CHK low order	82H	CRC CHK low order	3BH
	CRC CHK high order	C7H	CRC CHK high order	F3H
Fd-06	Current resolution read by communication	0: 0.01 A 1: 0.1 A	0	0xFD06/0x0D06
Fd-07	Software tool enabling selection	0: Disabled 1: Enabled	0	0xFD07/0x0D07
Group FE: User-defined Parameters				
FE-00	User-defined parameter 0	F0.00 to FP.xx A0.00 to Ax.xx U0.00 to U0.xx	F0.00	0xFE00/0x0E00
FE-01	User-defined parameter 1		F0.00	0xFE01/0x0E01
FE-02	User-defined parameter 2		F0.00	0xFE02/0x0E02
FE-03	User-defined parameter 3		F0.00	0xFE03/0x0E03
FE-04	User-defined parameter 4		F0.00	0xFE04/0x0E04
FE-05	User-defined parameter 5		F0.00	0xFE05/0x0E05
FE-06	User-defined parameter 6		F0.00	0xFE06/0x0E06
FE-07	User-defined parameter 7		F0.00	0xFE07/0x0E07
FE-08	User-defined parameter 8		F0.00	0xFE08/0x0E08
FE-09	User-defined parameter 9		F0.00	0xFE09/0x0E09
FE-10	User-defined parameter 10		F0.00	0xFE0A/0x0E0A
FE-11	User-defined parameter 11		F0.00	0xFE0B/0x0E0B

Param. No.	Param. Name	Setting Range	Default	Communication Address
FE-12	User-defined parameter 12	F0.00 to FP.xx A0.00 to Ax.xx U0.00 to U0.xx	F0.00	0xFE0C/0x0E0C
FE-13	User-defined parameter 13		F0.00	0xFE0D/0x0E0D
FE-14	User-defined parameter 14		F0.00	0xFE0E/0x0E0E
FE-15	User-defined parameter 15		F0.00	0xFE0F/0x0E0F
FE-16	User-defined parameter 16		F0.00	0xFE10/0x0E10
FE-17	User-defined parameter 17		F0.00	0xFE11/0x0E11
FE-18	User-defined parameter 18		F0.00	0xFE12/0x0E12
FE-19	User-defined parameter 19		F0.00	0xFE13/0x0E13
FE-20	User-defined parameter 20		F0.00	0xFE14/0x0E14
FE-21	User-defined parameter 21		F0.00	0xFE15/0x0E15
FE-22	User-defined parameter 22		F0.00	0xFE16/0x0E16
FE-23	User-defined parameter 23		F0.00	0xFE17/0x0E17
FE-24	User-defined parameter 24		F0.00	0xFE18/0x0E18
FE-25	User-defined parameter 25		F0.00	0xFE19/0x0E19
FE-26	User-defined parameter 26		F0.00	0xFE1A/0x0E1A
FE-27	User-defined parameter 27		F0.00	0xFE1B/0x0E1B
FE-28	User-defined parameter 28		F0.00	0xFE1C/0x0E1C
FE-29	User-defined parameter 29		F0.00	0xFE1D/0x0E1D
FE-30	User-defined parameter 30		F0.00	0xFE1E/0x0E1E
FE-31	User-defined parameter 31		F0.00	0xFE1F/0x0E1F
<b>Group FP: Parameter Management</b>				
FP-00	User password	0 to 65535	0	0x1F00



### 3 Parameters

Param. No.	Param. Name	Setting Range	Default	Communication Address
FP-01	Industry macro instruction	0: No operation 01: Restore factory parameters except motor parameters 02: Clear records 03: Reserved 04: Back up current user parameters 05 to 19: Reserved 20: Mechanical moving (conveyor belt) industry 21: Inertia (fan) industry 22 to 500: Reserved 501: Restore user backup parameters	0	0x1F01
For details, see "3.2 Industry Macro instructions."				
FP-02	Parameter group display selection	Ones position: Group U display 0: Hidden 1: Displayed Tens position: Group A display 0: Hidden 1: Displayed	11	0x1F02
This parameter is used to display or hide the parameters in groups U and A. By default, the parameters in groups U and A are displayed.				
FP-04	Parameter modification property	0: Can be modified 1: Cannot be modified	0	0x1F04
<b>Group A0: Torque Control (Only available in "-INT" version)</b>				
A0-00	Torque control	0: Speed control 1: Torque control	0	0xA000/0x4000
A0-01	Drive torque upper limit source	0: Set by A0-03 (Drive torque upper limit) 1: AI1 2: AI2 3: AI3 4: Pulse setting 5: Communication setting 6: Min. (AI1, AI2) 7: Max. (AI1, AI2)	0	0xA001/0x4001
A0-03	Drive torque upper limit	-200% to +200%	150.0%	0xA003/0x4003
A0-05	Maximum forward frequency in torque control	0.00 Hz to F0-10 (Maximum frequency)	50.00 Hz	0xA005/0x4005
A0-06	Maximum reverse frequency in torque control	0.00 Hz to F0-10 (Maximum frequency)	50.00 Hz	0xA006/0x4006
A0-07	Torque acceleration time	0.0 to 650.00s	0.00s	0xA007/0x4007
A0-08	Torque deceleration time	0.0 to 650.00s	0.00s	0xA008/0x4008

Param. No.	Param. Name	Setting Range	Default	Communication Address
Group A1: Function setting for AI used as DI				
A1-00	Reserved		0	0xA100/0x4100
A1-01	Reserved		0	0xA101/0x4101
A1-02	Reserved		0	0xA102/0x4102
A1-03	Reserved		0	0xA103/0x4103
A1-04	Reserved		0	0xA104/0x4104
A1-05	Reserved		00000	0xA105/0x4105
A1-06	Reserved		00000	0xA106/0x4106
A1-07	Function selection for AI used as DI	0 to 52	0	0xA107/0x4107
A1-10	Active state selection for AI used as DI	0: High level active 1: Low level active Ones position: AI1 Tens position: AI2 (Reserved) Hundreds position: AI3 (Reserved)	10	0xA10A/0x410A
A1-11	Reserved		0	0xA10B/0x410B
A1-12	Reserved		0	0xA10C/0x410C
A1-13	Reserved		0	0xA10D/0x410D
A1-14	Reserved		0	0xA10E/0x410E
A1-15	Reserved		0	0xA10F/0x410F
A1-16	Reserved		0.0s	0xA110/0x4110

### 3 Parameters

Param. No.	Param. Name	Setting Range	Default	Communication Address
A1-17	Reserved		0.0s	0xA111/0x4111
A1-18	Reserved		0.0s	0xA112/0x4112
A1-19	Reserved		0.0s	0xA113/0x4113
A1-20	Reserved		0.0s	0xA114/0x4114
A1-21	Reserved		00000	0xA115/0x4115
<b>Group A5: Control Optimization Parameters</b>				
A5-00	DPWM switchover frequency upper limit	0.00 Hz to maximum frequency	12.00 Hz	0xA500/0x4500
<p>It is used to determine the wave modulation mode in V/F control of the asynchronous motor. If the frequency is lower than the value of this parameter, the waveform is 7-segment continuous modulation. If the frequency is higher than the value of this parameter, the waveform is 5-segment intermittent modulation.</p> <p>The 7-segment continuous modulation causes more loss to switches of the AC drive but smaller current ripple. The 5-segment intermittent modulation causes less loss to switches of the AC drive but larger current ripple. This may lead to motor running instability at high frequency. Do not modify this parameter generally.</p> <p>For details about the loss and temperature rise of the AC drive, see the description of F0-15 (Carrier frequency).</p>				
A5-02	Dead zone compensation mode	0: No compensation 1: Compensation mode 1	1	0xA502/0x4502
<p>Try to use a different compensation mode only when there is special requirement on the waveform quality of the output voltage or oscillation occurs on the motor. Generally, this parameter needs no modification.</p>				
A5-03	Random PWM depth	0: Random PWM invalid 1 to 10: Random PWM depth	0	0xA503/0x4503
<p>This parameter is used to lower the unpleasant motor noise and reduce the electromagnetic interference.</p> <p>If this parameter is set to 0, random PWM is invalid. You will obtain different results by adjusting the random PWM depth.</p>				
A5-04	Fast current limit	0: Disabled 1: Enabled	1	0xA504/0x4504
<p>This function can be enabled to minimize the possibility of AC drive overcurrent faults, guaranteeing uninterrupted running of the AC drive.</p> <p>However, long-time rapid current limit may overheat the AC drive, which is not allowed. In this case, the AC drive will report Err40, indicating that the AC drive is overloaded and needs to stop.</p>				
A5-05	Maximum output voltage coefficient	100 to 110	103	0xA505/0x4505

Param. No.	Param. Name	Setting Range	Default	Communication Address
<p>This parameter indicates the boost capacity of maximum voltage of the AC drive. Increasing the value of this parameter will improve the maximum loading capacity in the motor flux weakening area. Be aware that this may lead to an increase in motor current ripple and an increase in motor heating. Decreasing the value of this parameter will reduce the motor current ripple and motor heating. Be aware that this will lower the maximum loading capacity in the motor flux weakening area. Generally, this parameter needs no modification.</p>				
A5-06	Undervoltage threshold	140.0 V to 420.0 V	Single-phase: 200.0 V Three-phase: 350.0 V	0xA506/0x4506
<p>This parameter is used to set the voltage upon which the AC drive undervoltage fault Err09 (A09 at stop) is reported.</p>				
A5-08	Low speed carrier frequency upper limit	0.0 to 6.0 kHz	0	0xA508/0x4508
A5-09	Overvoltage threshold	300.0 V to 820.0 V	Single-phase: 410.0 V Three-phase: 820.0 V	0xA509/0x4509
<p>This parameter is used to set the voltage upon which the AC drive overvoltage fault is reported. Note: The default value is the AC drive overvoltage protection upper limit. This parameter is valid only when the value is lower than the default value. If the value is higher than the default value, the default value will be used.</p>				
<b>Group A6: AI Curve Setting</b>				
A6-24	Jump point of AI1 input corresponding setting	-100.0% to +100.0%	0.0%	0xA618/0x4618
A6-25	Jump amplitude of AI1 input corresponding setting	0.0% to 100.0%	0.5%	0xA619/0x4619
A6-26	Jump point of AI2 input corresponding setting	-100.0% to +100.0%	0.0%	0xA61A/0x461A
A6-27	Jump amplitude of AI2 input corresponding setting	0.0% to 100.0%	0.5%	0xA61B/0x461B
<b>Group A9: Reserved</b>				
A9-00 to A9-29	Reserved	-	-	0xA900/0x4900 to 0xA91D/0x491D

### 3 Parameters

Param. No.	Param. Name	Setting Range	Default	Communication Address
Group AA: Vector Control Extension Parameters				
AA-05	Speed filter in SVC mode	5 ms to 32 ms	15 ms	0xAA05/0x4A05
AA-06	Speed feedback mode in SVC mode	0 to 3	0	0xAA06/0x4A06
AA-07	Magnetic field adjustment bandwidth in SVC mode	0.5 Hz to 8.0 Hz	4.0 Hz	0xAA07/0x4A07
AA-08	Low-speed exciting current given in SVC mode	30% to 150%	100	0xAA08/0x4A08
AA-09	Switchover frequency under open-loop control	2.0 Hz to 100.0 Hz	4.0 Hz	0xAA09/0x4A09
AA-10	Speed fluctuation reduction coefficient under open-loop control	0 to 6	3	0xAA0A/0x4A0A
AA-11	Acceleration/Deceleration time under open-loop control	0.1s to 1000.0s	50.0s	0xAA0B/0x4A0B
AA-12	Resistance auto-tuning upon startup	0: Disabled 1: Enabled	0	0xAA0C/0x4A0C
AA-13	Stator resistance auto-tuning coefficient 1 before startup	0 to 65535	Auto-tuning parameter	0xAA0D/0x4A0D
AA-14	Stator resistance auto-tuning coefficient 2 before startup	0 to 65535	Auto-tuning parameter	0xAA0E/0x4A0E
AA-15	Stator resistance auto-tuning coefficient 3 before startup	0 to 65535	Auto-tuning parameter	0xAA0F/0x4A0F
Group AC: AI/AO Correction				
AC-00	AI measured voltage 1	-10.00 V to +10.000 V	Factory-corrected	0xAC00/0x4C00
AC-01	AI displayed voltage 1	-10.00 V to +10.000 V	Factory-corrected	0xAC01/0x4C01
AC-02	AI measured voltage 2	-10.00 V to +10.000 V	Factory-corrected	0xAC02/0x4C02
AC-03	AI displayed voltage 2	-10.00 V to +10.000 V	Factory-corrected	0xAC03/0x4C03

Param. No.	Param. Name	Setting Range	Default	Communication Address
AC-12	AO target voltage 1	-10.00 V to +10.000 V	Factory-corrected	0xAC0C/0x4C0C
AC-13	AO measured voltage 1	-10.00 V to +10.000 V	Factory-corrected	0xAC0D/0x4C0D
AC-14	AO target voltage 2	-10.00 V to +10.000 V	Factory-corrected	0xAC0E/0x4C0E
AC-15	AO measured voltage 2	-10.00 V to +10.000 V	Factory-corrected	0xAC0F/0x4C0F
Note: By default, the parameters in groups A1, A5, and AC are not displayed. You can set FP-02 (Parameter display property) to display them.				
Group AE: AI/AO Factory-corrected Values				
AE-00	AI1 measured voltage 1	-9.999 V to +4.000 V	2.000 V	0xAE00/0x4E00
AE-01	AI1 sampling voltage 1	-9.999 V to +4.000 V	2.000 V	0xAE01/0x4E01
AE-02	AI1 measured voltage 2	-9.999 V to +9.999 V	8.000 V	0xAE02/0x4E02
AE-03	AI1 sampling voltage 2	-9.999 V to +9.999 V	8.000 V	0xAE03/0x4E03
AE-12	AO1 ideal voltage 1	0.500 V to 4.000 V	2.000 V	0xAE0C/0x4E0C
AE-13	AO1 measured voltage 1	0.500 V to 4.000 V	2.000 V	0xAE0D/0x4E0D
AE-14	AO1 ideal voltage 2	6.000 V to 9.999 V	8.000 V	0xAE0E/0x4E0E
AE-15	AO1 measured voltage 2	6.000 V to 9.999 V	8.000 V	0xAE0F/0x4E0F

Group U0: Monitoring Parameters					
Param. No.	Param. Name	Communication Address	Param. No.	Param. Name	Communication Address
U0-00	Running frequency (Hz)	0x7000	U0-25	Current power-on time (min)	0x7019
U0-01	Frequency reference (Hz)	0x7001	U0-26	Current running time (min)	0x701A
U0-02	Bus voltage (V)	0x7002	U0-27	Pulse input frequency (Hz)	0x701B
U0-03	Output voltage (V)	0x7003	U0-28	Communication reference (%)	0x701C
U0-04	Output current (A)	0x7004	U0-30	Main frequency X display (Hz)	0x701E
U0-05	Output power (kW)	0x7005	U0-31	Auxiliary frequency Y display (Hz)	0x701F
U0-06	Output torque (%)	0x7006	U0-32	Viewing any register address value	0x7020
U0-07	DI state	0x7007	U0-35	Target torque (%)	0x7023
U0-08	DO state	0x7008	U0-37	Power factor angle	0x7025
U0-09	AI voltage (V)	0x7009	U0-39	Target voltage upon V/F separation (V)	0x7027

Group U0: Monitoring Parameters					
Param. No.	Param. Name	Communication Address	Param. No.	Param. Name	Communication Address
U0-10	Communication protocol display	0x700A	U0-40	Output voltage upon V/F separation (V)	0x7028
U0-11	External operating panel potentiometer voltage (V)	0x700B	U0-41	DI state display	0x7029
U0-12	Count value	0x700C	U0-42	DO state display	0x702A
U0-13	Length value	0x700D	U0-45	Fault information	0x702D
U0-14	Load speed display	0x700E	U0-59	Reserved	0x703B
U0-15	PID reference	0x700F	U0-60	Reserved	0x703C
U0-16	PID feedback	0x7010	U0-61	AC drive running status	0x703D
U0-17	PLC stage	0x7011	U0-62	Current fault	0x703E
U0-18	Pulse input frequency (kHz)	0x7012	U0-63	Reserved	0x703F
U0-19	Feedback speed (Hz)	0x7013	U0-64	Number of slaves in master/slave control (displayed on the master)	0x7040
U0-20	Remaining running time (min)	0x7014	U0-65	Torque upper limit (%)	0x7041
U0-21	AI voltage before correction	0x7015	U0-69	Motor frequency (Hz)	0x7045
U0-22	External operating panel potentiometer voltage before correction	0x7016	U0-71	Communication-specific current display (A)	0x7047
U0-24	Motor speed (rpm)	0x7018	U0-78	Linear speed	0x704E

## 3.2 Industry Macro Instructions

For the MD200 AC drive, the industry macro instruction parameters can be set for realizing optimal settings in industry applications.

FP-01 (Industry macro) is used to correlate the parameter settings with the industry applications. After it is set, optimal settings will be adopted for related parameters automatically.

Mechanical moving (conveyor belt) industry: Used for applications requiring multi-speed, short starting time, and smooth acceleration/deceleration (FP-01 = 20).

Inertia (fan) industry: Used for applications requiring analog control and prohibiting reverse running (FP-01 = 21).

The following figure shows the settings for enabling the industry macro mode.

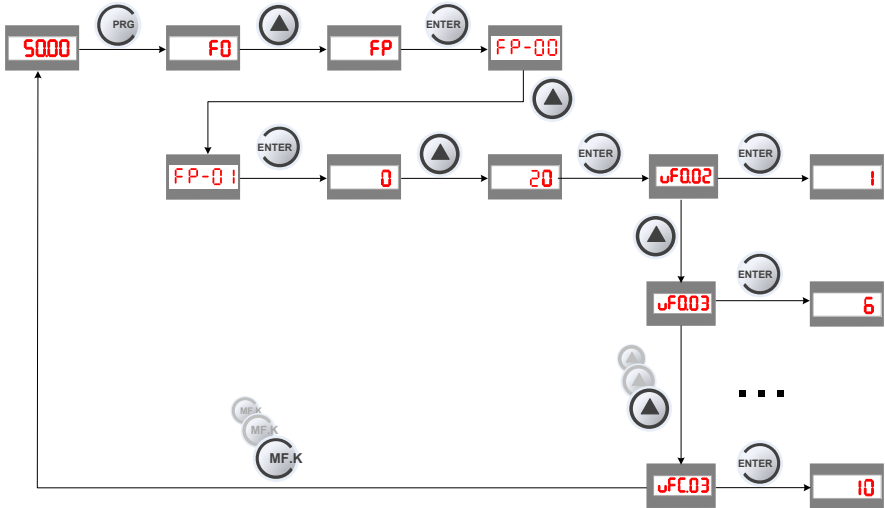

The following figure shows the settings for disabling the industry macro mode.

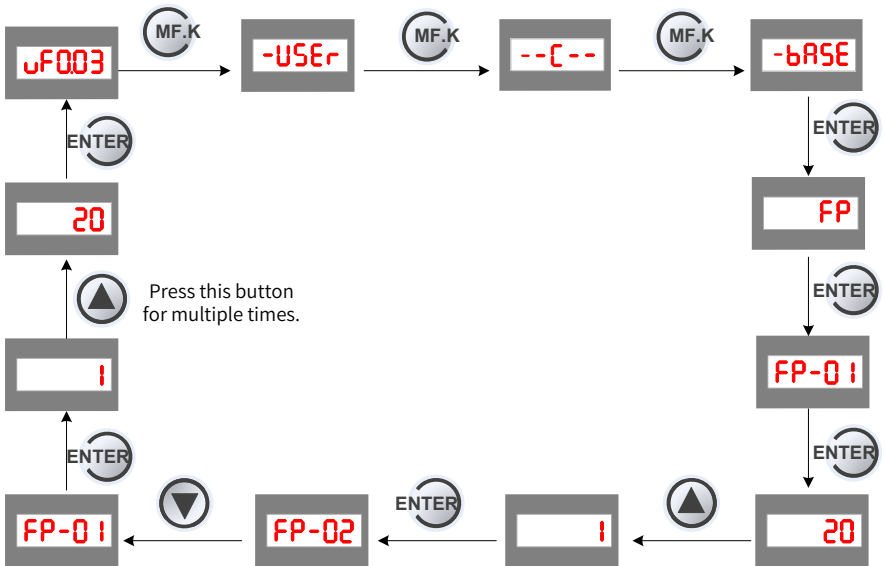

The following table lists the industry macro parameters and optimal settings.



Industry Macro Instruction	Related Parameter	Optimal Value
FP-01 = 20 Mechanical moving (conveyor belt) industry  Used for applications requiring multi-speed, short starting time, and smooth acceleration/deceleration.	F0-02 Command source selection	1: Terminal I/O control
	F0-03 Main frequency source X selection	6: Multi-reference
	F0-08 Preset frequency	50 Hz
	F0-10 Maximum frequency	50 Hz
	F0-17 Acceleration time	3.0s
	F0-18 Deceleration time	3.0s
	F3-18 Current limit level	150%
	F3-20 Current limit gain	20
	F4-01 DI2 function selection	2
	F4-02 DI3 function selection	12
	F4-03 DI4 function selection	13
	F4-10 DI filter time	0.100s
	F6-07 Acceleration/Deceleration mode	2: Dynamic S-curve acceleration/deceleration
	F6-11 DC injection braking start frequency	0.5 Hz
	F6-13 Shutdown DC injection braking current	50%
	F6-14 Shutdown DC injection braking active time	1s
	FC-00 Reference 0	10%
FC-01 Reference 1	100%	
FC-02 Reference 2	75%	
FC-03 Reference 3	10%	
FP-01 = 21 Inertia (fan) industry  Used for applications requiring analog control and prohibiting reverse running.	F0-02 Command source selection	1: Terminal I/O control
	F0-03 Main frequency source X selection	2: AI
	F0-08 Preset frequency	50 Hz
	F0-10 Maximum frequency	50 Hz
	F0-15 Carrier frequency	6.0 kHz
	F3-00 V/f curve setting	0: Linear V/f
	F3-18 Current limit level	150%
	F3-20 Current limit gain	20
	F6-00 Start mode	1: Flying start
	F8-13 Reverse run control	1: Disabled
	F9-09 Fault auto reset times	3
	F9-11 Auto fault reset interval	1.0s
	F9-59 Power dip ride-through function selection	1: Decelerate

### 3.3 Communication Addresses

The MD200 series AC drive provides the RS232/RS485 communication interface and supports the Modbus communication protocol. Using a PC or PLC, you can implement centralized control by setting AC drive running commands, modifying or reading parameters, and reading AC drive working status and faults.

Note: The communication addresses of the AC drive parameters (such as parameters in groups F, A, and U) are listed at the last column in the parameter table. The communication addresses described in this section are communication addresses of special control words and status words.

The communication address definitions for the stop/run parameters are as follows.

Parameter Address	Parameter Description	Parameter Address	Parameter Description
1000	Communication setting value (-10000 to +10000) (decimal)	1011	PID feedback
1001	Running frequency	1012	PLC process
1002	Bus voltage	1013	Pulse input frequency (unit: 0.01 kHz)
1003	Output voltage	1014	Feedback speed (unit: 0.01 Hz)
1004	Output current	1015	Remaining running time
1005	Output power	1016	AI voltage before correction
1006	Output torque	1017	External operating panel potentiometer voltage before correction
1007	Running speed	1018	Reserved
1008	DI input indication	1019	Motor speed
1009	DO output indication	101A	Current power-on time
100A	AI voltage	101B	Current running time
100B	Reserved	101C	Pulse input frequency (unit: 1 Hz)
100C	External operating panel potentiometer voltage	101D	Communication setting
100D	Counting value input	101E	Reserved
100E	Length value input	101F	Main frequency X display
100F	Load speed	1020	Auxiliary frequency Y display
1010	PID reference		

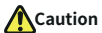

**Caution**

- ◆ The communication setting value is the percentage of the relative value. For example, +10000 and -10000 correspond to +100.00% and -100.00%, respectively.
- ◆ For frequency dimension data, this percentage is a percentage of relative maximum frequency (F0-10).

### 3 Parameters

Type	Communication Address	Read/Write Range		
Control command input (write-only)	2000	0001: Forward running 0002: Reverse running 0003: Forward jogging	0004: Reverse jogging 0005: Coast to stop	0006: Decelerate to stop 0007: Fault reset
State reading (read-only)	3000	0001: Forward running	0002: Reverse running	0003: Stop
Parameter locking password check	1F00	***** (If 8888H is returned, the password check is passed.)		
DO control (write-only)	2001	BIT0: (Reserved) BIT1: (Reserved) BIT2: RELAY1 output control BIT3: (Reserved)	BIT4: (Reserved) BIT5: VDO1 BIT6: VDO2	BIT7: VDO3 BIT8: VDO4 BIT9: VDO5
AO control (write-only)	2002	0 to 7FFF indicate 0% to 100% .		
AC drive fault description	8000	0000: No fault 0001: Reserved 0002: Overcurrent during acceleration 0003: Overcurrent during deceleration 0004: Overcurrent at constant speed 0005: Overvoltage during acceleration 0006: Overvoltage during deceleration 0007: Overvoltage at constant speed 0008: Pre-charge resistor overload 0009: Undervoltage 000A: AC drive overload 000B: Motor overload 000C: Input phase loss	000D: Output phase loss 000E: IGBT overheat 000F: External fault 0010: Communication abnormal 0011: Reserved 0012: Current detection fault 0013: Motor auto-tuning fault 0014: Reserved 0015: Parameter read/write abnormal 0016: Reserved 0017: Motor short circuit to ground 0018: Reserved 0019: Reserved	001A: Running time reached 001B: User-defined fault 1 001C: User-defined fault 2 001D: Power-on time reached 001E: Load loss 001F: PID feedback lost during running 0028: Fast current limit timeout 0029: Reserved 002A: Reserved 002B: Reserved 002D: Reserved 0033: Reserved 0037: Slave fault in speed synchronization

Type	Communication Address	Read/Write Range		
Communication fault information description data (fault code)	8001H	0000: No fault 0001: Password incorrect 0002: Command code incorrect	0003: CRC check error 0004: Invalid address 0005: Invalid parameter	0006: Parameter modification invalid 0007: System locked 0008: Under EEPROM operation

When Fd-05 (Data transmission format) is set to 1 (Standard Modbus protocol), the relationships between the standard protocol error codes and current error codes are as below.

Standard Protocol Error Code	Corresponding Current Error Code
01: Command code incorrect	0002: Command code incorrect
02: Address incorrect	0004: Invalid address
03: Data error	0005: Invalid parameter; 0001: Password incorrect
04: Command cannot be processed	0006: Parameter modification invalid; 0007: System locked

## 4 Troubleshooting

### 4.1 Fault Codes and Solutions

The AC drive has almost 25 pieces of alarm information and protective functions. If a fault occurs, the AC drive stops output, the contact of the fault relay works, and the fault code is displayed on the operating panel. Before seeking help, you can find the possible causes and rectify the fault according to the instructions in this chapter. If the fault cannot be rectified, contact the agent or Inovance for technical support. The following table describes the faults and solutions.

Fault Name	Fault Code	Possible Cause	Solution
Overcurrent during acceleration	Err02	<ol style="list-style-type: none"> <li>1. The output circuit of the AC drive is grounded or short circuited.</li> <li>2. The acceleration time is too short.</li> <li>3. The customized torque boost or V/f curve is not appropriate.</li> <li>4. The voltage is too low.</li> <li>5. The motor is started while rotating.</li> <li>6. A sudden load is applied during acceleration.</li> <li>7. The AC drive power class is too low.</li> <li>8. The resistance of the braking resistor is too low or the braking resistor is short circuited.</li> <li>9. The motor is short-circuited to ground.</li> </ol>	<ol style="list-style-type: none"> <li>1. Eliminate external faults.</li> <li>2. Increase the acceleration time.</li> <li>3. Adjust the customized torque boost or V/f curve.</li> <li>4. Adjust the voltage to the normal range.</li> <li>5. Enable the flying start function or start the motor after it stops.</li> <li>6. Remove the added load.</li> <li>7. Select an AC drive of higher power class.</li> <li>8. Replace the braking resistor.</li> <li>9. Replace the cable or motor.</li> </ol>
Overcurrent during deceleration	Err03	<ol style="list-style-type: none"> <li>1. The output circuit of the AC drive is grounded or short circuited.</li> <li>2. The deceleration time is too short.</li> <li>3. The voltage is too low.</li> <li>4. A sudden load is applied during deceleration.</li> <li>5. A braking resistor is not installed.</li> <li>6. The resistance of the braking resistor is too low or the braking resistor is short circuited.</li> <li>7. The motor is short-circuited to ground.</li> </ol>	<ol style="list-style-type: none"> <li>1. Eliminate external faults.</li> <li>2. Increase the deceleration time.</li> <li>3. Adjust the voltage to the normal range.</li> <li>4. Remove the added load.</li> <li>5. Install a braking resistor.</li> <li>6. Replace the braking resistor.</li> <li>7. Replace the cable or motor.</li> </ol>

Fault Name	Fault Code	Possible Cause	Solution
Overcurrent at constant speed	Err04	<ol style="list-style-type: none"> <li>1. The output circuit of the AC drive is grounded or short circuited.</li> <li>2. The voltage is too low.</li> <li>3. A sudden load is applied during running.</li> <li>4. The AC drive power class is too low.</li> <li>5. The resistance of the braking resistor is too low or the braking resistor is short circuited.</li> <li>6. The motor is short-circuited to ground.</li> </ol>	<ol style="list-style-type: none"> <li>1. Eliminate external faults.</li> <li>2. Adjust the voltage to the normal range.</li> <li>3. Remove the added load.</li> <li>4. Select an AC drive of higher power class.</li> <li>5. Replace the braking resistor.</li> <li>6. Replace the cable or motor.</li> </ol>
Overvoltage during acceleration	Err05	<ol style="list-style-type: none"> <li>1. The input voltage is too high.</li> <li>2. An external force drives the motor during acceleration.</li> <li>3. The acceleration time is too short.</li> <li>4. A braking resistor is not installed.</li> </ol>	<ol style="list-style-type: none"> <li>1. Adjust the voltage to the normal range.</li> <li>2. Cancel the external force or install a braking resistor.</li> <li>3. Increase the acceleration time.</li> <li>4. Install a braking resistor.</li> </ol>
Overvoltage during deceleration	Err06	<ol style="list-style-type: none"> <li>1. The input voltage is too high.</li> <li>2. An external force drives the motor during deceleration.</li> <li>3. The deceleration time is too short</li> <li>4. A braking resistor is not installed.</li> </ol>	<ol style="list-style-type: none"> <li>1. Adjust the voltage to the normal range.</li> <li>2. Cancel the external force or install a braking resistor.</li> <li>3. Increase the deceleration time.</li> <li>4. Install a braking resistor.</li> </ol>
Overvoltage at constant speed	Err07	<ol style="list-style-type: none"> <li>1. The input voltage is too high.</li> <li>2. An external force drives the motor during running.</li> </ol>	<ol style="list-style-type: none"> <li>1. Adjust the voltage to the normal range.</li> <li>2. Cancel the external force or install a braking resistor.</li> </ol>
Control power fault	Err08	<ol style="list-style-type: none"> <li>1. The input voltage is not within the allowable range.</li> </ol>	<ol style="list-style-type: none"> <li>1. Adjust the input voltage to the normal range.</li> </ol>
Undervoltage	Err09	<ol style="list-style-type: none"> <li>1. An instantaneous power failure occurs.</li> <li>2. The AC drive's input voltage is not within the allowable range.</li> <li>3. The bus voltage is abnormal.</li> <li>4. The rectifier bridge and pre-charge resistor are faulty.</li> <li>5. The driver board is faulty.</li> <li>6. The control board is faulty.</li> </ol>	<ol style="list-style-type: none"> <li>1. Reset the fault.</li> <li>2. Adjust the voltage to the normal range.</li> <li>3. Contact the agent or Inovance.</li> <li>4. Contact the agent or Inovance.</li> <li>5. Contact the agent or Inovance.</li> <li>6. Contact the agent or Inovance.</li> </ol>

Fault Name	Fault Code	Possible Cause	Solution
AC drive overload	Err10	<ol style="list-style-type: none"> <li>1. The load is too heavy or locked-rotor occurs on the motor.</li> <li>2. The AC drive power class is too low.</li> </ol>	<ol style="list-style-type: none"> <li>1. Reduce the load and check the motor and mechanical conditions.</li> <li>2. Replace the AC drive by one with higher power class.</li> </ol>
Motor overload	Err11	<ol style="list-style-type: none"> <li>1. F9-01 (Motor overload protection gain) is set incorrectly.</li> <li>2. The load is too heavy or locked-rotor occurs on the motor.</li> <li>3. The AC drive power class is too low.</li> </ol>	<ol style="list-style-type: none"> <li>1. Set F9-01 (Motor overload protection gain) properly.</li> <li>2. Reduce the load and check the motor and mechanical conditions.</li> <li>3. Select an AC drive of higher power class.</li> </ol>
Input phase loss	Err12	<ol style="list-style-type: none"> <li>1. The three-phase power input is abnormal.</li> <li>2. The driver board is faulty.</li> <li>3. The surge protection device is abnormal.</li> <li>4. The main control board is faulty.</li> </ol>	<ol style="list-style-type: none"> <li>1. Eliminate external faults.</li> <li>2. Contact the agent or Inovance.</li> <li>3. Contact the agent or Inovance.</li> <li>4. Contact the agent or Inovance.</li> </ol>
Output phase loss	Err13	<ol style="list-style-type: none"> <li>1. The cable connecting the AC drive and the motor is faulty.</li> <li>2. The three-phase outputs of the AC drive are unbalanced when the motor is running.</li> <li>3. The driver board is faulty.</li> <li>4. The IGBT is faulty.</li> </ol>	<ol style="list-style-type: none"> <li>1. Eliminate external faults.</li> <li>2. Check whether the motor three-phase winding is normal and eliminate the fault.</li> <li>3. Contact the agent or Inovance.</li> <li>4. Contact the agent or Inovance.</li> </ol>
IGBT overheat	Err14	<ol style="list-style-type: none"> <li>1. The ambient temperature is too high.</li> <li>2. The air filter is blocked.</li> <li>3. The fan is damaged.</li> <li>4. The thermistor of the IGBT is damaged.</li> <li>5. The inverter module is faulty.</li> </ol>	<ol style="list-style-type: none"> <li>1. Reduce the ambient temperature.</li> <li>2. Clean the air filter.</li> <li>3. Replace the AC drive.</li> <li>4. Replace the AC drive.</li> <li>5. Replace the AC drive.</li> </ol>
External device fault	Err15	<ol style="list-style-type: none"> <li>1. An external fault signal is input through the DI.</li> <li>2. An external fault signal is input through the virtual I/O.</li> </ol>	<ol style="list-style-type: none"> <li>1. Reset the fault.</li> <li>2. Reset the fault.</li> </ol>
Communication fault	Err16	<ol style="list-style-type: none"> <li>1. The host controller is abnormal.</li> <li>2. The communication cable is faulty.</li> <li>3. The communication parameters in group Fd are set incorrectly.</li> </ol>	<ol style="list-style-type: none"> <li>1. Check wiring of the host controller.</li> <li>2. Check the communication cabling.</li> <li>3. Set communication parameters in group Fd properly.</li> </ol>
Current detection fault	Err18	The driver board is abnormal.	Replace the AC drive.

Fault Name	Fault Code	Possible Cause	Solution
Motor auto-tuning fault	Err19	1. The motor parameters are not set according to the nameplate. 2. The auto-tuning times out.	1. Set the motor parameters according to the nameplate properly. 2. Check the cables connecting the AC drive and the motor.
EEPROM read-write fault	Err21	The EEPROM chip is damaged.	Replace the AC drive.
Short circuit to ground	Err23	1. The motor is short-circuited to ground. 2. The upper IGBT of the AC drive is damaged, which needs to be determined by skilled personnel.	1. Replace the cable or motor. 2. Replace the AC drive.
Accumulative running time reached	Err26	1. The accumulative running time reaches the set value.	1. Clear the record by parameter initialization.
User-defined fault 1	Err27	1. The signal of user-defined fault 1 is input through the DI. 2. The signal of user-defined fault 1 is input through the virtual I/O.	1. Reset the fault. 2. Reset the fault.
User-defined fault 2	Err28	1. The signal of user-defined fault 2 is input through the DI. 2. The signal of user-defined fault 2 is input through the virtual I/O.	1. Reset the fault. 2. Reset the fault.
Accumulative power-on time reached	Err29	The accumulative power-on time reaches the set value.	Clear the record by parameter initialization.
Load loss	Err30	The operation current of the AC drive is lower than F9-64 (Load loss detection level).	Check whether the load is disconnected or ensure that F9-64 (Load loss detection level) and F9-65 (Load loss detection time) are set based on the actual conditions.
PID feedback loss during running	Err31	The PID feedback is lower than the value of FA-26 (Detection level of PID feedback loss).	Check the PID feedback signal or set FA-26 (Detection level of PID feedback loss) correctly.
Pulse-by-pulse current limit fault	Err40	1. The load is too heavy or locked-rotor occurs on the motor. 2. The AC drive power class is too low.	1. Reduce the load and check the motor and mechanical conditions. 2. Select an AC drive of higher power class.



Fault Name	Fault Code	Possible Cause	Solution
Large speed error	Err42	<ol style="list-style-type: none"> <li>1. Locked-rotor occurs on the motor.</li> <li>2. F9-69 (Detection level of speed error) and F9 -70 (Detection time of speed error) are set incorrectly.</li> <li>3. The cable connecting the output side (UVW) of the AC drive and the motor is faulty.</li> </ol>	<ol style="list-style-type: none"> <li>1. Check the mechanical conditions. Check whether motor auto-tuning is performed and whether F2-10 (Digital setting of torque limit in speed control) is set too low.</li> <li>2. Set F9-69 (Detection level of speed error) and F9-70 (Detection time of speed error) correctly based on actual conditions.</li> <li>3. Check the cables connecting the AC drive and the motor.</li> </ol>
Slave fault in speed synchronization	Err55	When the speed synchronization function is enabled, Err55 (point-to-point slave fault) is reported if the master receives CAN communication data but fails to detect the slave.	<ol style="list-style-type: none"> <li>1. Check the CAN communication cabling of the slave.</li> <li>2. Check whether the CAN communication of the slave is normal.</li> </ol>

## 4.2 Symptoms and Solutions

The following symptoms may occur during use of the AC drive. When these symptoms occur, perform simple analysis based on the following table.

No.	Fault Symptom	Possible Cause	Solution
1	There is no display upon power-on.	<ol style="list-style-type: none"> <li>1. There is no power supply to the AC drive or the power input to the AC drive is too low.</li> </ol> The AC drive is damaged.	<ol style="list-style-type: none"> <li>1. Check the power supply. Replace the AC drive.</li> </ol>
2	"HC" is displayed upon power-on.	The cable connecting the driver board and the control board is in poor contact. Related components on the control board are damaged. The motor or the motor cable is short circuited to the ground. The mains voltage is too low.	Re-connect the 4-core and 28-core cables. Contact the agent or Inovance.
3	Err14 (IGBT overheat) is detected frequently.	The carrier frequency is set too high. The cooling fan is damaged, or the air filter is blocked. Components (thermocouple or others) inside the AC drive are damaged.	Reduce F0-15 (Carrier frequency). Replace the cooling fan and clean the air filter. Contact the agent or Inovance.

No.	Fault Symptom	Possible Cause	Solution
4	The motor does not rotate after the AC drive runs.	The cabling between the AC drive and the motor is abnormal. The motor parameters in group F1 are set incorrectly. The driver board is faulty.	Check that cabling between the AC drive and the motor is normal. Replace the motor or rectify mechanical faults. Check and set the motor parameters again.
5	DI terminals are disabled.	The related parameters are set incorrectly. The external signal is incorrect. The control board is faulty.	Check and reset the parameters in group F4 again. Re-connect the external signal cable. Contact the agent or Inovance.
6	The AC drive detects overcurrent and overvoltage frequently.	The motor parameters in group F1 are set incorrectly. The acceleration/deceleration time is improper. The load fluctuates.	Set the motor parameters properly. Set proper acceleration/ deceleration time. Contact the agent or Inovance.

## 5 Technical Data and Model Selection

### 5.1 Overall Dimensions

The following figure shows the overall dimensions of the MD200 series AC drive.

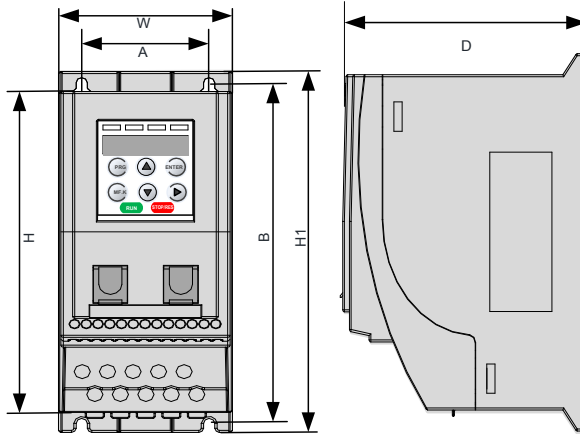

Overall Dimensions (mm)				Mounting Hole Dimensions (mm)		Mounting Hole Diameter (mm)	Weight (kg)
H1	H	W	D	A	B		
180	160	75	145	55	170	Φ5.0	1.1

### 5.2 Technical Data

#### 5.2.1 Rated Data

Table 5-1 AC drive models and technical data (single phase 220 V to 240 V)

Item		Specification			
MD200SXX(B)(-NC)		0.4	0.75	1.5	2.2
Applicable motor capacity (kW)		0.4	0.75	1.5	2.2
Output	Rated output current (A)	2.5	4.6	8.0	11.0
	Output voltage	Three phase 0 to 240 VAC			
	Maximum output frequency	500 Hz (editable through a parameter)			
	Carrier Frequency	0.8 kHz to 8.0 kHz (automatically adjusted according to the load characteristics)			
	Overload capacity	150% for 60s with rated current			

Item		Specification			
Power supply	Rated input current (A)	6.5	11.0	18.0	27.0
	Rated voltage and frequency	Single-phase 200 V to 240 V, 50/60 Hz			
	Allowed voltage fluctuation	-15% to +10%; actual allowed range: 170 VAC to 264 VAC			
	Allowed frequency fluctuation	±5%			
	Power capacity (kVA)	1.7	3.0	4.8	7.1
Thermal design	Thermal power consumption (kW)	17.800	34.170	64.800	95.390
	Air flow (CFM)	10.5	10.5	15.0	15.0
Overvoltage category		OVC III			
Pollution degree		PD2			
IP rating		IP20			
Weight (kg)		1.3			

Table 5-2 AC drive models and technical data (three phase 380 V to 480 V)

Item		Specification				
MD200TXX(B)(-NC)		0.4	0.75	1.5	2.2	3.7
Applicable motor capacity (kW)		0.4	0.75	1.5	2.2	3.7
Output	Rated Output Current (A)	1.8	3.4	4.8	5.5	9.5
	Output voltage	Three phase 0 to 480 VAC				
	Maximum output frequency	500 Hz (editable through a parameter)				
	Carrier frequency	0.8 kHz to 8.0 kHz (automatically adjusted according to the load characteristics)				
	Overload capacity	150% for 60s with rated current				
Power supply	Rated input current (A)	2.6	4.5	5.5	6.5	11.0
	Rated voltage and frequency	Three-phase 380 VAC to 480 VAC, 50/60 Hz				
	Allowed voltage fluctuation	-15% to +10%; actual allowed range: 323 VAC to 528 VAC				
	Allowed frequency fluctuation	±5%; actual allowed range: 47.5 Hz to 63 Hz				
	Power capacity (kVA)	1.0	1.5	3.0	4.0	5.9
Thermal design	Thermal power consumption (kW)	17.540	24.980	44.930	58.580	108.910
	Air flow (CFM)	10.5	10.5	15.0	15.0	15.0
Overvoltage category		OVC III				
Pollution degree		PD2				
IP rating		IP20				
Weight (kg)		1.4				

## 5.2.2 Technical Specifications

	Item	Specification
Standard functions	Maximum frequency	V/f control: 0 to 500 Hz SVC: 0 to 500 Hz (only for three phase)
	Carrier frequency	0.8 kHz to 12 kHz The carrier frequency is automatically adjusted based on the load features.
	Input frequency resolution	Digital setting: 0.01 Hz; Analog setting: maximum frequency x 0.025%
	Control mode	V/f control SVC (only for three phase)
	Overload capacity	60s for 150% with the rated current, 2s for 180% with the rated current
	Torque boost	Automatic boost; Customized boost 0.1 % to 30.0 %
	V/f curve	Linear V/f curve Multi-point V/f curve
	Acceleration/Deceleration curve	Linear acceleration/deceleration or dynamic S-curve with two groups of acceleration/deceleration time in the range of 0.0 to 6500.0s
	DC injection braking	DC injection braking frequency: 0.00 Hz to 10.00 Hz DC injection braking active time: 0.0s to 100.0s Current level of DC injection braking: 0% to 100%
	Jog control	Frequency range of jog running: 0.00 to 50.00 Hz Acceleration/Deceleration time of jog running: 0.0s to 6500.0s
	Multi-speed running	Up to 8 preset speeds can be selected through control terminals.
	Built-in PID	The system implements the proportional–integral–derivative (PID) function in the closed-loop control.
	Automatic voltage regulation (AVR)	Keeps constant output voltage automatically when the mains voltage changes.
	Overvoltage/Overcurrent stall control	The system limits the output current and voltage automatically during operation to prevent frequent or excessive trips.
	Fast current limit	The function helps to avoid frequent overcurrent faults.
	Power dip ride-through	The load feedback energy compensates for any voltage reduction, allowing the AC drive to continue operating for a short period during power dips. The RUN indicator on the operating panel blinks after power dip ride-through is enabled.
Timing control	Time range: 0.0 to 6500.0 min	
Communication bus	Two field buses are supported, including RS485 and CANlink.	

Item		Specification
Running	Command source	Operating panel setting Control terminal setting Serial communication setting You can perform switchover between these sources in various ways.
	Frequency source	Five frequency sources: Digital setting, analog voltage setting, analog current setting, pulse setting (DI4), and communication setting. You can perform switchover between these sources in various ways.
	Auxiliary frequency source	Five auxiliary frequency sources are provided for fine tuning of the auxiliary frequency and main & auxiliary calculation.
	Input terminals	Four DI terminals, one of which supports up to 20 kHz high-speed pulse input One AI terminal that supports 0 to 10 V/0 to 20 mA input
	Output terminals	One relay output terminal One AO terminal that supports 0 to 10 V voltage output
	I/O terminals	One DI/DO terminal. The DI or DO function is selected by using the DIP switch. See Figure 2-2 for details. The DO common terminal is COM.
	Communication terminal	One RS-485 communication terminal. Customized CANlink communication is supported.
Operating panel & display (format)	LED display	Shows parameters.
	Key locking and function selection	Keys on the control panel can be locked partially or electronically to prevent accidental operation.
	Protections	Motor short-circuit detection upon power-on, input/output phase loss protection, overcurrent protection, overvoltage protection, undervoltage protection, overheat protection, and overload protection
Environment	Operating location	Free from direct sunlight, dust, corrosive gas, combustible gas, oil mist, vapor, drip, or salt indoor
	Altitude	Maximum altitude: 3000 m. In places where the altitude exceeds 1000 m and the cooling effect deteriorates due to the thin air, the AC drive needs to be derated by 1% for per 100 m increase.
	Ambient temperature	-10°C to +50°C (derating required in the range of 40°C to 50°C )
	Humidity	Less than 95% RH, non-condensing
	Vibration	Lower than 5.9m/s <sup>2</sup> (0.6g)
	Storage temperature	-20°C to +60°C
	IP rating	IP20
Mains	Applicable mains	TN or TT

## 5.3 Selection of Electrical Peripherals

AC Drive Model	Air Switch (MCCB) (A)	Recommended Contactor (A)	Recommended Main Circuit Cable (mm <sup>2</sup> )	Recommended Main Circuit Lug Model	Torque of Torque Driver (N·m)	Recommended Control Circuit Cable (mm <sup>2</sup> )	Recommended Input Fuse Bussmann (Compliant with UL Certification)	
							Rated Current	Model
Single-phase power supply: 220 V								
MD200S0.4(B) (-NC)	10	9	0.75	TVS1.25-4S	0.87	0.5	12	JKS-12
MD200S0.75(B) (-NC)	16	12	1.5	TVS1.25-4S	0.87	0.5	20	JKS-20
MD200S1.5(B) (-NC)	32	25	2.5	TVS2.0-4S	0.87	0.5	35	JKS-32
MD200S2.2(B) (-NC)	40	32	4.0	TVS3.5-4S	0.87	0.5	50	JKS-50
Three-phase power supply: 380 V								
MD200T0.4B(-NC)	6	9	0.75	TVS1.25-4S	0.87	0.5	5	KTK-5
MD200T0.75B(-NC)	10	9	0.75	TVS1.25-4S	0.87	0.5	8	KTK-8
MD200T1.5B(-NC)	10	9	0.75	TVS1.25-4S	0.87	0.5	10	KTK-10
MD200T2.2B(-NC)	10	9	0.75	TVS1.25-4S	0.87	0.5	12	KTK-12
MD200T3.7B(-NC)	16	12	1.5	TVS1.25-4S	0.87	0.5	20	KTK-20

## 5.4 Selection of the EMC Filter

### 5.4.1 Internal (Built-in) EMC Filter

Single-phase models with standard built-in C3 EMC filters as standard, are able to meet the EN61800-3 category C3 emission limits, in order to comply with the requirements of CE certification.

### 5.4.2 External Filter

- Optional external filter single-phase models

By using external EMC filters, single-phase models are able to meet the EN61800-3 category C2 emission limits, in order to comply with the requirements of CE certification.

- ◆ Keep the connection cable between the filter and the drive as short as possible (shorter than 30 cm). Ensure that the EMC filter and the AC drive are connected to the same grounding surface. The output ground terminal of the EMC filter must be connected to the input grounding terminal of the AC drive. The EMC filter must be reliably grounded to ensure the filter effect.



Caution

AC Drive Model	Power Capacity (kVA)	Input Current (A)	Recommended Filter Model (Schaffner)	Recommended Filter Model (Jianli)
Single-phase power supply: 220 V, 50/60 Hz; Range: -15% to +10%				
MD200S0.4(B)(-NC)	1.7	6.5	FN 2090-8-06	DL-10TH3
MD200S0.75(B)(-NC)	3.0	11.0	FN 2090-12-06	DL-20TH1
MD200S1.5(B)(-NC)	4.8	18.0	FN 2090-20-08	DL-20TH1
MD200S2.2(B)(-NC)	7.1	27.0	FN 2090-30-08	DL-30TH1

1) Appearance



Schaffner series filter      Jianli series filter

2) Mounting dimensions

■ Dimensions of the Schaffner series filters

Outline drawings of FN 2090-8-06 and FN 2090-12-06:

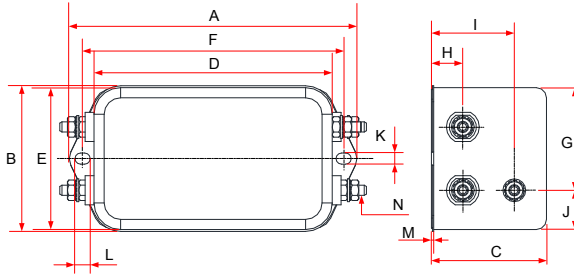

Outline drawings of N 2090-20-08 and FN 2090-30-08:

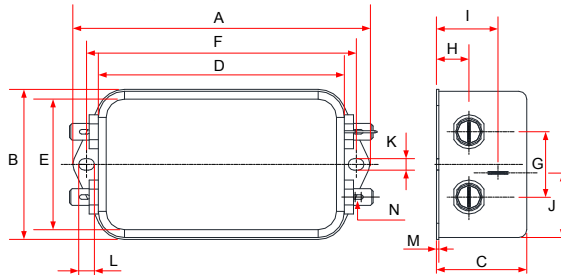

Reactor Model	A	B	C	D	E	F	G	H	I	J	K	L	M	N
FN 2090-8-06	113.5	57.5	45.4	94	56	103	25	12.4	32.4	15.5	4.4	6	0.9	6.3 × 0.8
FN 12/6/2090	113.5	57.5	45.4	94	56	103	25	12.4	32.4	15.5	4.4	6	0.9	6.3 × 0.8



Reactor Model	A	B	C	D	E	F	G	H	I	J	K	L	M	N
FN 2090-20-08	113.5	57.5	45.4	94	56	103	25	12.4	32.4	15.5	4.4	6	0.9	M4
FN 2090-30-08	113.5	57.5	45.4	94	56	103	25	12.4	32.4	15.5	4.4	6	0.9	M4

■ Dimensions of Jianli series filters

Outline drawings of DL-10TH3:

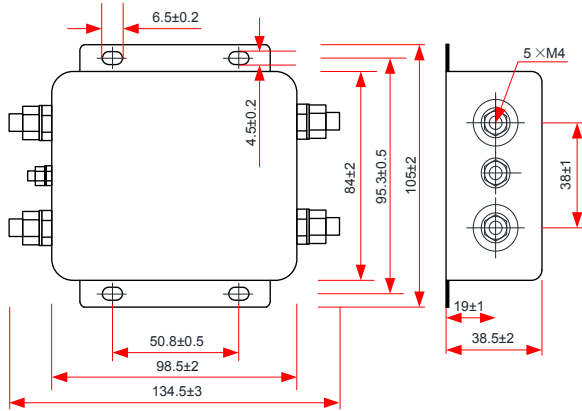

Outline drawings of DL-20TH1 and DL-30TH1

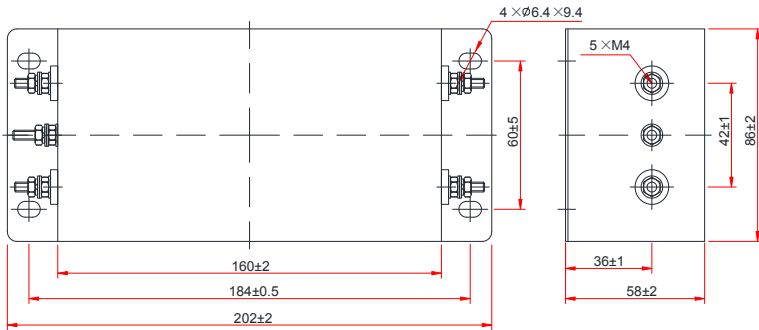

■ Optional external filter for three-phase models.

Three-phase models with optional external EMC filters are able to meet the EN61800-3 category C3 emission limits, in order to comply with the requirements of CE certification.



- ◆ Keep the connection cable between the filter and the drive as short as possible (shorter than 30 cm). Ensure that the EMC filter and the AC drive are connected to the same grounding surface. The output ground terminal of the EMC filter must be connected to the input grounding terminal of the AC drive. The EMC filter must be reliably grounded to ensure the filter effect.

AC Drive Model	Power Capacity (kVA)	Input Current (A)	Recommended Filter Model (Schaffner)	Recommended Filter Model (Jianli)
Three-phase power supply: 380 V, 50/60 Hz; Range: -15% to +10%				
MD200T0.4B(-NC)	1.0	2.6	FN3258-7-45	DL-5EBK5
MD200T0.75B(-NC)	1.5	4.5	FN3258-7-45	DL-5EBK5
MD200T1.5B(-NC)	3.0	5.5	FN3258-7-45	DL-10EBK5
MD200T2.2B(-NC)	4.0	6.5	FN3258-7-45	DL-10EBK5
MD200T3.7B(-NC)	5.9	11.0	FN3258-16-45	DL-16EBK5

### 3) Appearance



Schaffner series filter      Jianli series filter

### 4) Mounting dimensions

- Dimensions of the Schaffner series filters

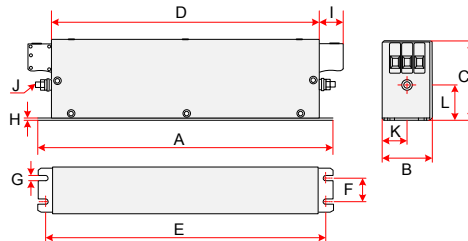

Reactor Model	(A)	B	C	D	E	F	G	H	I	J	K	L
FN3258-7-45	190	40	70	160	180	20	4.5	1	22	M5	20	29.5
FN3258-16-45	250	45	70	220	235	25	5.4	1	22	M5	22.5	29.5

■ Dimensions of Jianli series filters

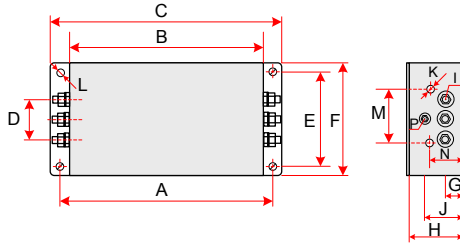

Reactor Model	A	B	C	D	E	F	G	H	I	J	K	M	N	P	L
DL-5EBK5															
DL-10EBK5	184	160	202	42	60	86	18	58	M4	38	-	-	-	M4	6.9 x 9.4
DL-16EBK5															

### 5.5 Selection of the AC Input Reactor

An AC reactor must be connected to the input side of the AC drive in series to reduce the current harmonics.

For the single-phase models, the inductance of the AC reactor must be higher than 8 mH to meet requirements of IEC 61000-3-12.

For the three-phase models, the inductance of the AC reactor must be higher than 5 mH to meet requirements of IEC 61000-3-12.

### 5.6 Selection of the dv/dt Output Reactor

When the motor output cable is longer than 100 m, reflected voltage is generated on the motor by the rising edge of the AC drive output pulse wave since the characteristic impedance of the motor does not match with that of the cable. The reflected voltage is added on the high voltage square wave pulse, bringing impact on the stator winding insulation. High-frequency harmonics brings greater heat loss and continuous impact of partial discharge pulses, causing quick motor failure under PWM pulse voltage. Therefore, when the motor cable is longer than 100 m, a dv/dt reactor must be installed on the output side.

## 1) Recommended output reactor models

AC Drive Model	Power Capacity (kVA)	Output Current (A)	Recommended dv/dt Output Reactor Model (Schaffner)	Output Reactor Inductance (mH)	Applicable Cable Length After Installing the dv/dt Reactor (m)
Single-phase power supply: 220 V, 50/60 Hz; Range: -15% to +10%					
MD200S0.4(B)(-NC)	1.7	2.6	RWK 305-4-KL	1.47	150
MD200S0.75(B)(-NC)	3.0	4.6	RWK 305-7.8-KL	0.754	150
MD200S1.5(B)(-NC)	4.8	8.0	RWK 305-10-KL	0.588	150
MD200S2.2(B)(-NC)	7.1	11.0	RWK 305-14-KL	0.42	150
Three-phase power supply: 380 V, 50/60 Hz; Range: -15% to +10%					
MD200T0.4B(-NC)	1.0	1.8	RWK 305-7.8-KL	0.754	150
MD200T0.75B(-NC)	1.5	3.4	RWK 305-7.8-KL	0.754	150
MD200T1.5B(-NC)	3.0	4.8	RWK 305-7.8-KL	0.754	150
MD200T2.2B(-NC)	4.0	5.5	RWK 305-7.8-KL	0.754	150
MD200T3.7B(-NC)	5.9	9.5	RWK 305-14-KL	0.42	150

## 2) Mounting dimensions of the dv/dt output reactor

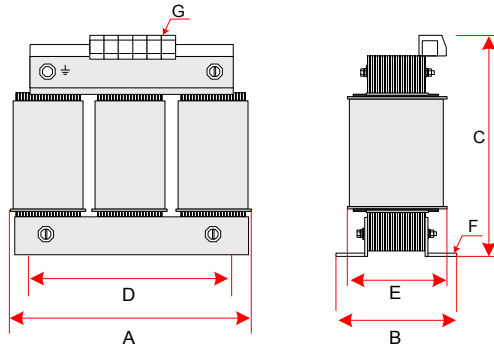

Reactor Model	(A)	B	C	D	E	F	G
RWK 305-4-KL	100	Max. 60	Max. 115	56	34	4.8 × 9	2.5 mm <sup>2</sup>
RWK 305-7.8-KL	100	Max. 60	Max. 115	56	34	4.8 × 9	2.5 mm <sup>2</sup>
RWK 305-10-KL	100	Max. 70	Max. 115	56	43	4.8 × 9	2.5 mm <sup>2</sup>
RWK 305-14-KL	125	Max. 70	Max. 135	100	45	5 × 8	2.5 mm <sup>2</sup>

## 5.7 Selection of Cables and Tightening Torque

Model	Terminal Symbol	Recommended UL Cable (AWG)	Screw	Tightening Torque (N·m)
Single-phase power supply: 220 V, 50/60 Hz; Range: -15% to +10%				
MD200S0.4(B)(-NC)	L1, L2	0.75	M4	1.2
	U, V, W	0.75		
	⊕	0.75		
MD200S0.75(B)(-NC)	L1, L2	1.5		
	U, V, W	0.75		
	⊕	0.75		
MD200S1.5(B)(-NC)	L1, L2	2.5		
	U, V, W	1.5		
	⊕	1.5		
MD200S2.2(B)(-NC)	L1, L2	4.0		
	U, V, W	2.5		
	⊕	2.5		
Three-phase power supply: 380 V, 50/60 Hz; Range: -15% to +10%				
MD200T0.4B(-NC)	R, S, T	0.75	M4	1.2
	U, V, W	0.75		
	⊕	0.75		
MD200T0.75B(-NC)	R, S, T	0.75		
	U, V, W	0.75		
	⊕	0.75		
MD200T1.5B(-NC)	R, S, T	1.5		
	U, V, W	0.75		
	⊕	0.75		
MD200T2.2B(-NC)	R, S, T	2.5		
	U, V, W	1.5		
	⊕	1.5		
MD200T3.7B(-NC)	R, S, T	4.0		
	U, V, W	2.5		
	⊕	2.5		

## 5.8 Selection of Optionals

Name	Model	Function	Remarks
External LCD Operating Panel	MDKE8	External LED operating panel	All models
	MDKE9	External LCD operating panel for parameter copy and display in English/Chinese	All models
External operating panel cable	MDCAB	Length: 3 m	All models
	MDCAB-1.5	Length: 1.5 m	All models
Guide rail installation accessory	MD200-DGJ1 (product code 01040023)	Guide rail installation accessory	All models

## Shenzhen Inovance Technology Co., Ltd.

Add.: Building E, Hongwei Industry Park, Liuxian Road, Baocheng No. 70 Zone, Bao'an District, Shenzhen

Tel: +86-755-2979 9595

Fax: +86-755-2961 9897

<http://www.inovance.com>

## Suzhou Inovance Technology Co., Ltd.

Add.: No. 16 Youxiang Road, Yuexi Town, Wuzhong District, Suzhou 215104, P.R. China

Tel: +86-512-6637 6666

Fax: +86-512-6285 6720

<http://www.inovance.com>



19010397A05

Copyright © Shenzhen Inovance Technology Co., Ltd.